

Note:
 All service laterals from the effluent sewer main to the property line shall be pressure tested prior to any backfilling. Typically tested with air compressor with \approx zero loss at 60 seconds. Typically installed below frost depth. Access risers shall not be located in vehicular traffic areas. Alternative HDPE valve box as an option for warmer climates.

Effluent Sewer Service Connection Detail



HDPE Self-Tapping Saddle

Tee Saddle Detail

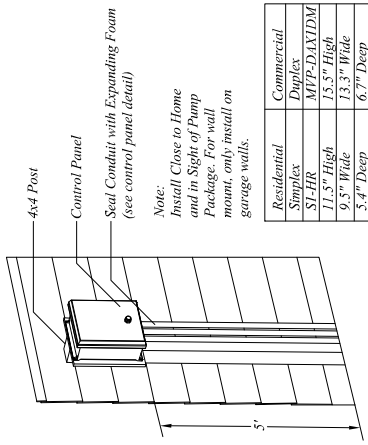

Control Panel Detail
 (Wall or 4x4 Post Mount)

Residential	Commercial
Simplex	Duplex
SI-HR	MVP-DALXDM
11.5" High	15.5" High
9.5" Wide	13.5" Wide
5.4" Deep	6.7" Deep

Note:
 Install Close to Home and in Sight of Pump Package. For wall mount, only install on garage walls.

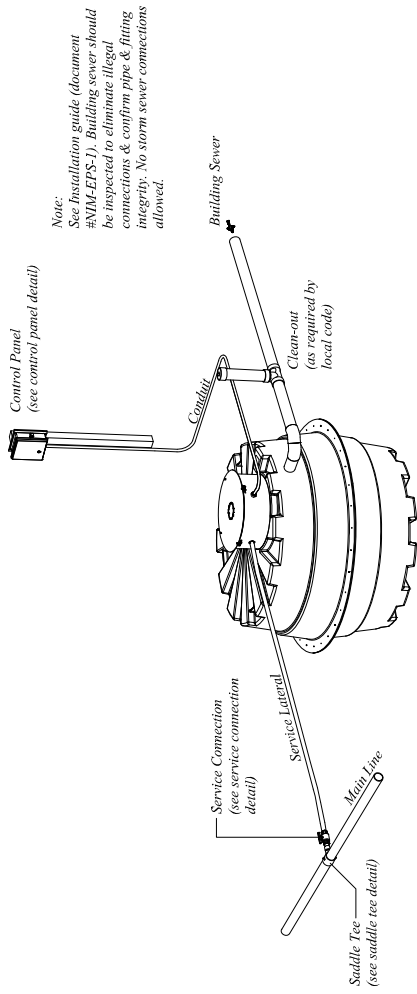

Typical Prelos Isometric View

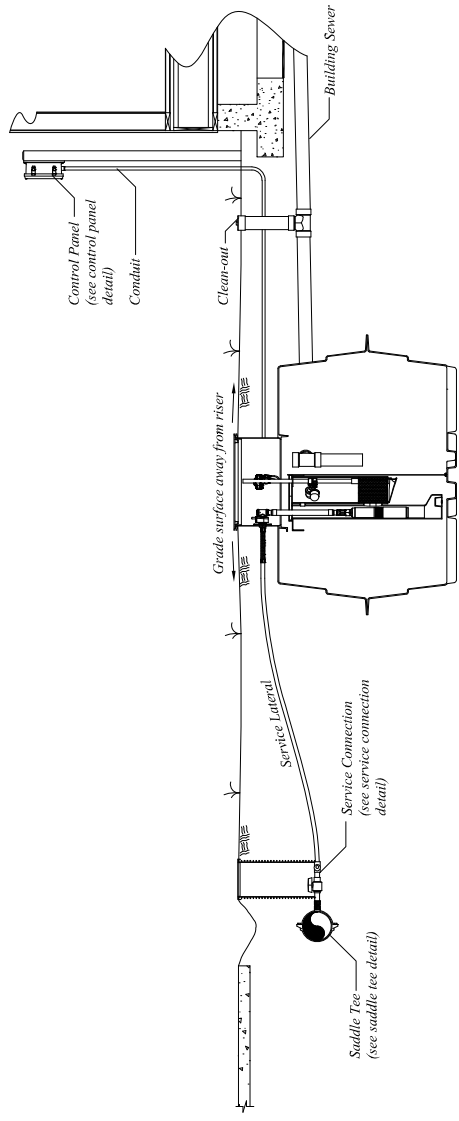

Typical Prelos Processor Detail

Disclaimer: This Proposed System Configuration Drawing is provided solely as a design aid and illustrates one possible configuration of a system that would comply with Orenco's design criteria for the requirements and/or specifications that have been communicated to Orenco Systems, Inc. Orenco Systems, Inc. does not assume any liability for the design, construction, or performance of the system. Design decisions regarding the actual layout and configuration of the system and its viability for the project, are at the sole discretion of the system's designer.

Orenco Systems, Inc. Portions of this Proposed System Configuration Drawing, as appropriate, may be reproduced and integrated into the site-specific layout and configuration of a system by its designer.



Project:	Prelos Sewer Details	Drawn By:	BAS / CSJ	Scale:	1" = 4'-0"
Description:	LOS Details Sheet 1	Reviewed By:	PF	Sheet:	1 OF 1
		File Name:	LOS DTL I.DWG	Rev:	2.0
				Date:	5/27/2021

General Notes:

Tank Volume: Total Volume: 1233 Gallons
 Operating Volume: 1000 Gallons @ 48"
 Cent volume at typical Operating Depth: 20 gal./in.

Looks: Top = 500 psf minimum
 Lateral Load = 62.4 psf, EFP
 Concentrated Wheel Load = 2500 lb.

The septic tank shall be capable of withstanding long-term hydrostatic loading, in addition to the soil loading, due to a water table maintained at ground surface.
 Soil Bearing = 1000 psf (re-evaluate support base if soil bearing is less or unequal)

Method of calculations:

1. Tanks shall be analyzed using strength design methods and finite element analysis for buried structures.
2. Calculations shall address the following:
 - buckling
 - deflection of 0.3 - 1% of the tank diameter, based on service load (including long-term deflection lag)
 - buoyancy
3. Performance testing shall include vacuum testing followed by a hydrostatic test.

Material: Resin: polydi-cyclopentadiene

The properties listed here along with the minimum thickness as shown in the details are considered design minimums that must be maintained during the manufacturing of the tanks. The primary strength properties are listed below:

Property:	DCPD	DCPD
Tensile modulus E_t	274,000 psi	9,200 psi
Tensile strength F_t	6,700 psi	7,180 psi
Flexural strength F_b	10,500 psi	583 psi

Poisson ratio = 0.400 (40% permanent metal part shall be 300 series stainless steel)

Installation: Installation, bedding, compaction, etc. shall be in "strict" compliance with the manufacturer's standards and state or local rules and/or guidelines. All tanks shall be level on a minimum 4 inch thick compacted sand or approved granular bedding over a firm uniform base. The base shall be stable and uniform in order to ensure equal bearing across the tank bottom. Installations with 18 inches or less of ground cover may require additional buoyancy considerations as described in the manufacturer's instructions. A minimum cover of 12 inches is required over the tank in areas subject to occasional light wheel loads. Refer to installation instructions Document NIM-LOS-1.

Test: Tanks shall be tested and certified watertight per manufacturer recommendations and/or any prevailing rules or guidelines, whichever is more restrictive.

Tank Markings: Place marking on the upper most surface over the outlet.

- Nominal Liquid capacity: 1000 gal. ±
- Max. burial depth: 5ft.
- Max. traffic (wheel): 2500 lbs.
- Date manufactured:
- Permit no.:

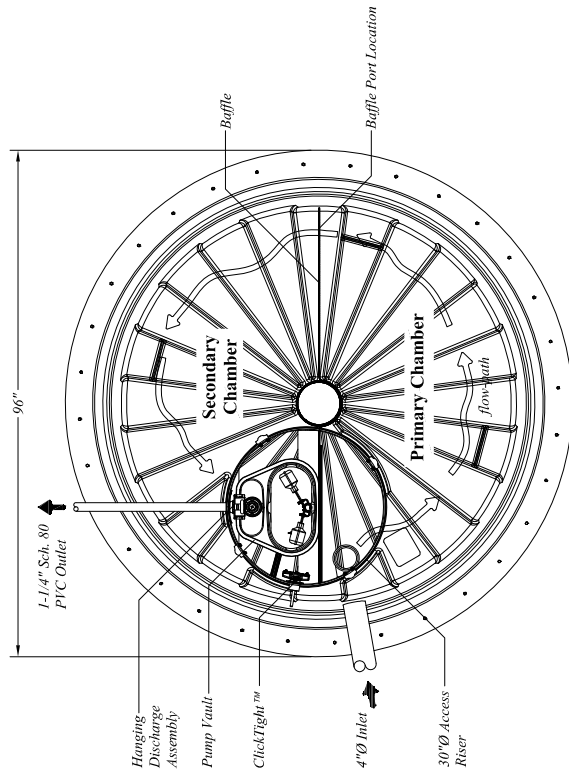

M1000 Tank Top Detail
 Scale: 1" = 2'-0"

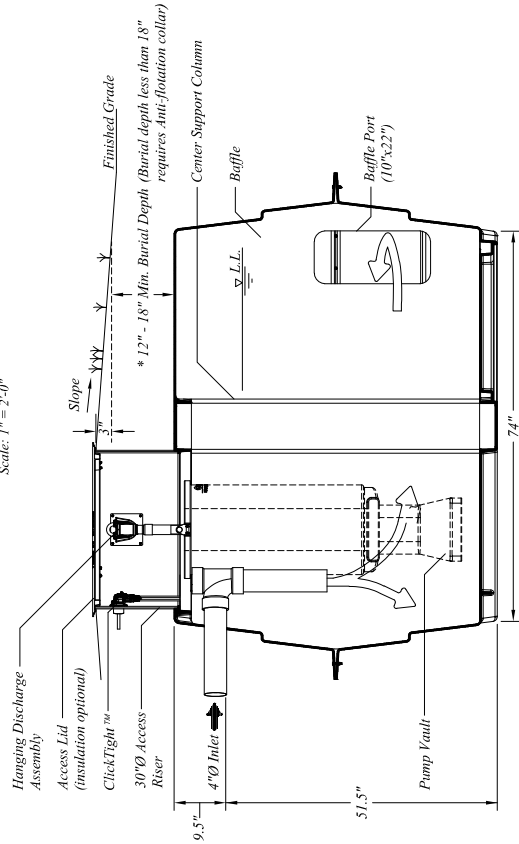

M1000 Tank Side Detail
 Scale: 1" = 2'-0"

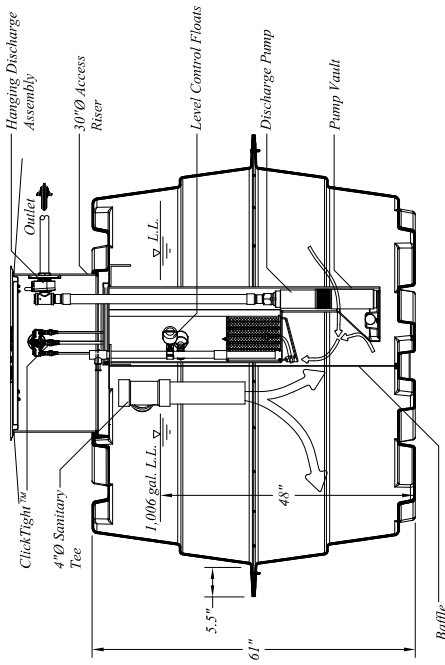
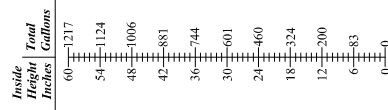

M1000 Tank End Detail
 Scale: 1" = 2'-0"



© Orengo Systems, Inc.
 Portions of this Proposed System Configuration Drawing, as appropriate, may be reproduced and integrated into the site-specific layout and configuration of a system by its designer.

Disclaimer: This Proposed System Configuration Drawing is provided solely as a design aid. It is not intended to be a substitute for the manufacturer's specifications. Orengo Systems, Inc. does not warrant the design criteria for the requirements and/or specifications that have been communicated to Orengo (based on third-party standards testing protocols and performance reports, as applicable). Design decisions, including the actual layout and configuration of the system and its viability for the project, are at the sole discretion of the system's designer.

Drawn By: BAS / CSJ
 Reviewed By: TB
 File Name: NIM-TP-LOS-100-1.DWG

Scale: 1" = 2'-0"

Scale: 1" = 2'-0"
 Sheet: 1 OF 1
 Rev: 3.0
 Date: 12/02/2021

DESIGN AID

Prelos 1000 Processor with
 Pump Discharge

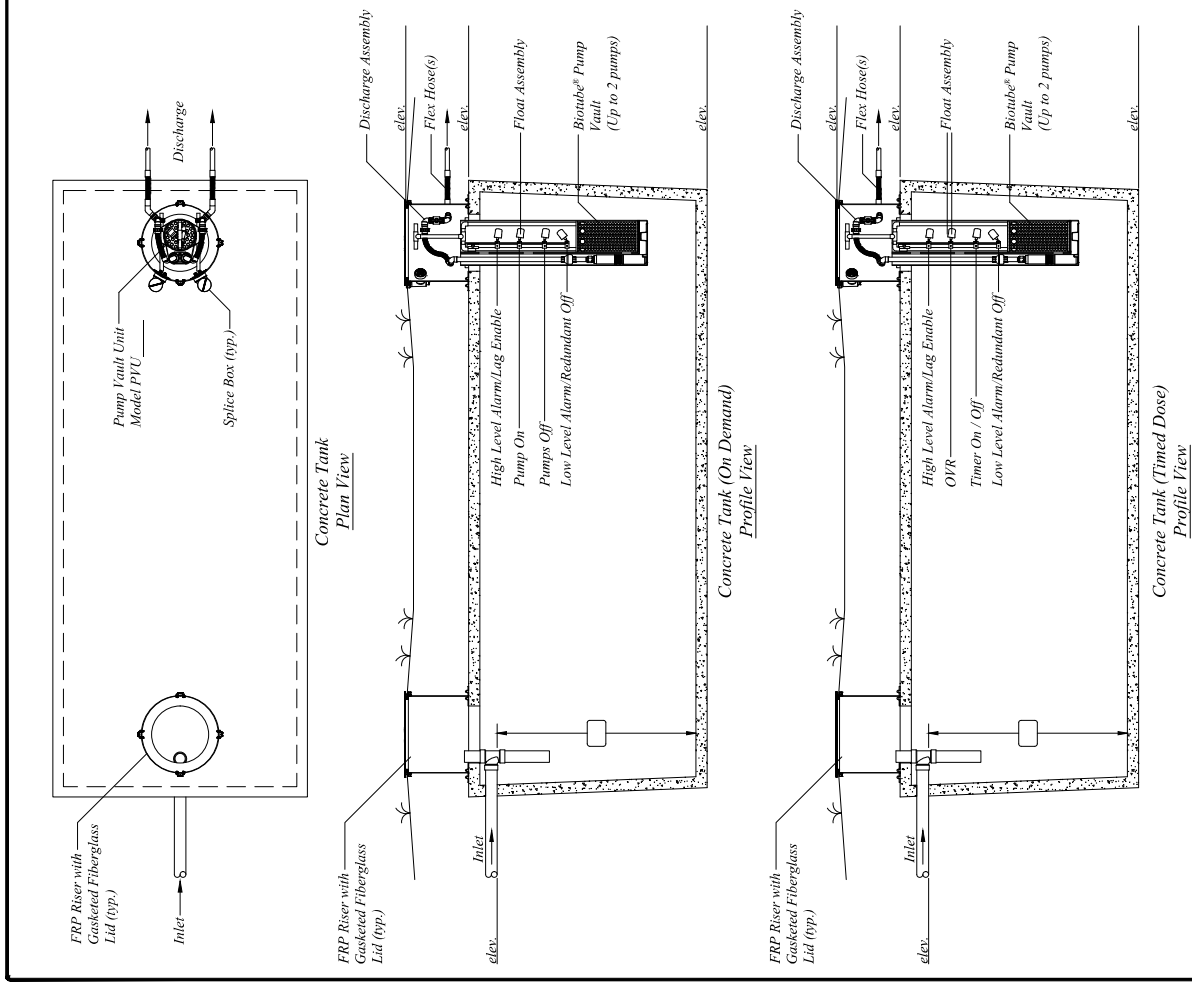
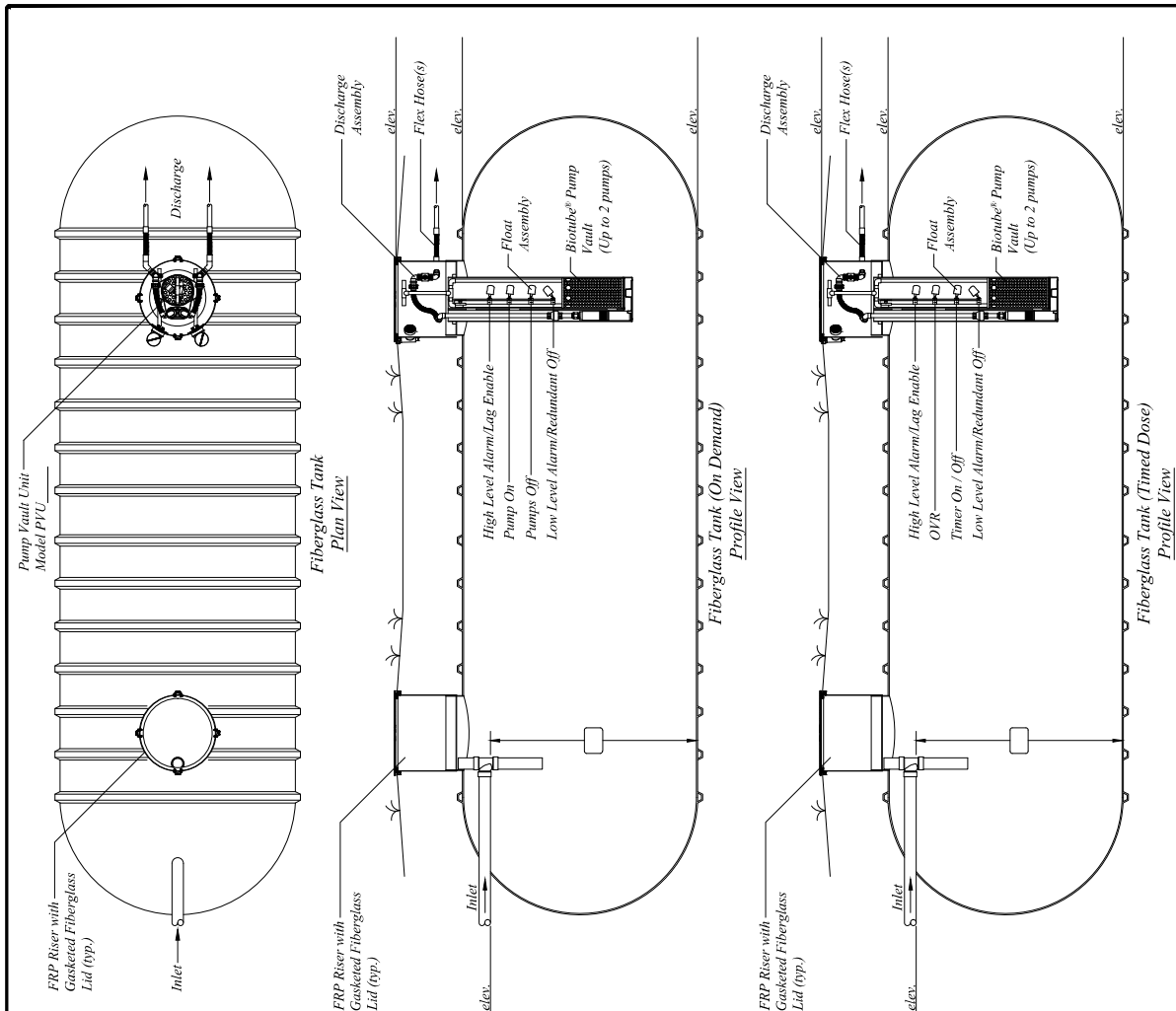

<p>Septic or Dose Tank with Pump Vault Unit Details</p> <p>Design Aid</p>		<p>Drawn By: BAS</p> <p>Reviewed By: GLE</p> <p>File Name: COMM PUMP TANK FIT DWG</p>	<p>Scale: NOT TO SCALE</p> <p>Sheet: 1 OF 1</p> <p>Rev: 2.0</p> <p>Date: 4/28/2022</p>
		<p>Disclaimer: This Proposed System Configuration Drawing is provided solely as a design aid and illustrates one possible configuration of a system that would comply with Orenco's design criteria for the requirements and/or specifications that have been communicated to Orenco (based on third-party standards testing protocols and performance reports, as applicable). Design decisions, including the actual layout and configuration of the system and its viability for the project, are at the sole discretion of the system's designer.</p>	

© Orenco Systems, Inc.
 Portions of or all this Proposed System Configuration Drawing, as appropriate, may be reproduced and integrated into the site-specific layout and configuration of a system by its designer.

Terrebonne, Oregon Prelos Sewer™ System Submittal Package

Project Name

Terrebonne STEP Collection System

Prepared for

Terrebonne Sanitary District

Prepared by

Johnathon Honeywell

Date

April 29, 2026

Prelos™ The Next Step In
Sewer Evolution



Prelos Collection Systems

Materials List

Quantity	Item	Documents
PRELOS1000-24A-Terrebonne		
1	M1000P M1000P: 30" riser opening	
1	PVPM52 Pump Vault Passive Meander - No Stem	
1	MF2P-1000-PVPM-CLK PVPM CLICKTIGHT FLOAT ASSEMBLY	
1	CLK2-60-NA ClickTight for 1 pump, 2 float connects; 62.5ft cable; 3/4" conduit; No RA	
1	PF100511CV-CLK 10GPM Pump, Internal Check Valve, ClickTight Connector	
1	HDAS30125FCASLC-32 Hanging Discharge Assy, 1.25",30" Riser,Simplex,FC,AS,LC,32" Hose Length	
1	HVX125PR 1 1/4" X 12" Hi-Press Ext. Flex Extension	
1	FLD30G-PRELOS Fiberglass Lid Durafiber, 30" W/EPDM Gasket, Prelos 4 bolts	
1	RF3024 30" x 24" Fiberglass Riser	
1	S1-HR Simplex Panel, 115V w/Redundant High-Level On	
Prelos1500-24A-Terrebonne		
1	M1500P 1500 Gallon; 30" Opening Only, Baffle location 120, Small Pass Through. Watertested	
1	PVPM65 Pump Vault Passive Meander - No Stem	
1	MF2P-1500-PVPM-CLK PVPM CLICKTIGHT FLOAT ASSEMBLY	
1	CLK2-60 ClickTight for 1 pump, 2 float connects; 62.5ft cable; 3/4" conduit	
1	PF100511CV-CLK 10GPM Pump, Internal Check Valve, ClickTight Connector	
1	HDAS30125FCASLC-32 Hanging Discharge Assy, 1.25",30" Riser,Simplex,FC,AS,LC,32" Hose Length	
1	HVX125PR 1 1/4" X 12" Hi-Press Ext. Flex Extension	NIN-HV-1 NTD-HV-HV-1
1	FLD30G-PRELOS Fiberglass Lid Durafiber, 30" W/EPDM Gasket, Prelos 4 bolts	
1	RF3024 30" x 24" Fiberglass Riser	NIN-RLA-RF-1 NTD-RLA-RF-1

Quantity	Item	Documents
1	S1-HR Simplex Panel, 115V w/Redundant High-Level On	
PSA10-Terrebone-Com		
1	FLD24G Fiberglass Lid, DuraFiber, 24" W/ EPDM Gasket; 4 bolts	NTD-GOP-FLS-1
1	RR-C RF3024+SX+XD+(2)12	
1	PRTA30 ABS Riser/Tank Adapter 30" Dia	NIN-TA-PRTA-2 NTD-RLA-PRTA-1
1	PRTA30BDKIT Bolt Down Kit, PRTA30	NIN-TA-PRTA-2 NTD-RLA-PRTA-1
1	MA8120 Methacrylate Adhesive & Activator, 1:1 Ratio(300ml.ea) Work Time 20-30 min.	NTD-ADH-1
1	PVU57-1819 Universal Biotube Pump Vault , 18" cartridge	NIN-PVU-1-PRN NTD-PVU-1
1	MF3P-27V Float Assembly; 27" Stem, Pump Vault	
2	PF100511CV Effluent Pump; 1/2Hp, 10gpm, 115V, 60Hz, 10' Lead,"w/Internal Check Valve"	XLD-PU-PF-1 NTD-PU-PF-1
2	HV125BC Hose & Valve Assembly, 1.25"	NIN-HV-1 NTD-HV-HV-1
2	HVX125PR 1 1/4" X 12" Hi-Press Ext. Flex Extension	NIN-HV-1 NTD-HV-HV-1
1	SBEX1-4 PVC Splice Box w/ 1 - 4 Cord Grips Available	NIN-SB-SBEX-1 NTD-SBEX-1
1	SBX-D Explosion-Proof Splice Box, Duplex	NIN-SB-SBX-1 NTD-SB-SBX-1
1	MVP-DAX1IRDM MVP Duplex Panel, 115V	

Prelos1000-24A-Terrebonne

Orenco Prelos® 1000 Processor

Applications

Orenco's Prelos 1000 Processor provides complete, integrated storage, filtration, and pumping of wastewater for on-lot portions of Prelos Sewer systems and other pressurized liquid-only sewers or dispersal systems.

General

The Prelos Processor is the core of the Prelos Sewer System: an innovative technology based on 40 years of proven sewer solutions. The tank stores and passively treats solid waste, while the patent-pending pump vault and filter separate and pump liquid effluent.*

All Prelos 1000 Processors install as a unit, to reduce errors. The 30in (750mm) diameter access riser provides easy access to the tank interior, and the passively self-cleaning filter can be removed without removing the pump vault, pump, or discharge assembly, simplifying O&M and keeping related costs down.

* Tank covered under United States Patent #10,392,281

Standard Model

PRELOS1000-18, PRELOS1000-24, PRELOS1000-30, PRELOS1000-36, PRELOS1000-48, PRELOS1000-60

Product Code Diagram

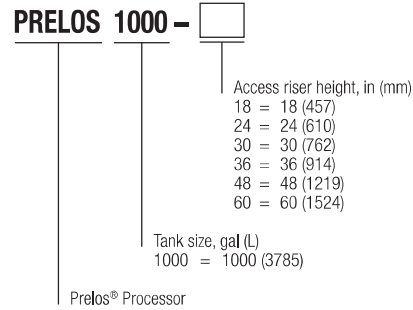

The Prelos 1000 Processor offers complete, integrated storage and pumping of wastewater in a simple, effective package.

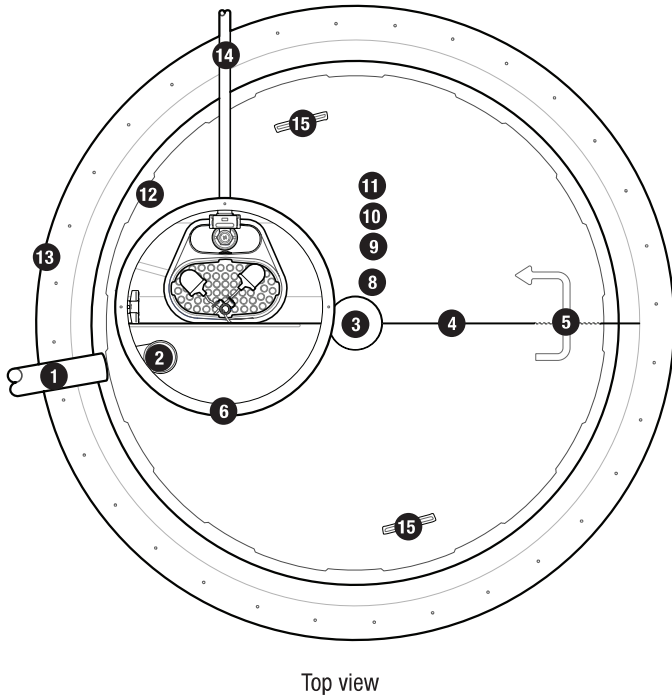
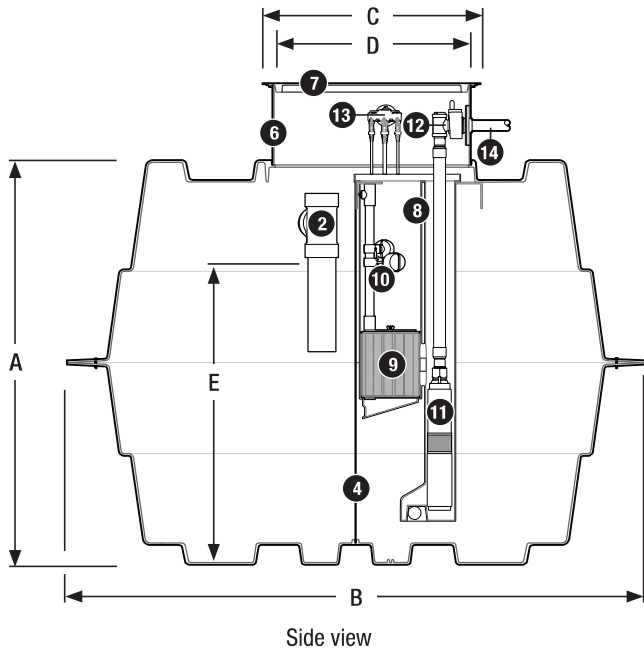

- | | | |
|------------------------------|---------------------------|------------------------|
| 1. Inlet | 6. Access riser | 11. Pump |
| 2. Inlet tee | 7. Access lid | 12. Discharge assembly |
| 3. Support column | 8. Pump vault | 13. ClickTight™ |
| 4. Baffle wall (full-length) | 9. Biotube® filter | 14. Discharge |
| 5. Baffle pass-through | 10. Float switch assembly | 15. Lifting bracket |

Tank, Riser, and Lid

The Prelos 1000 Processor's meander-style tank has a patented design for superior performance. It's tough, impact resistant, and light enough to install with small equipment. The single 30in (750mm) access riser and access lid are designed to provide strong, secure access to components inside of the Prelos 1000 Processor.

Materials of Construction

Access lid	Fiber-reinforced polymer (FRP), structural foam
Access lid hardware	Stainless steel
Access riser	FRP
Inlet and inlet tee	ABS
Baffle wall	ABS
Support column	PVC, ABS
Tank body	DCPD

Dimensions

A Tank height, in (mm)	61 (1549)
B Tank outside diameter, in (mm)	96 (2438)
C Lid outside diameter, in (mm)	33 (838)
D Riser inside diameter, in (mm)	29.5 (749)
E Depth, nominal operating volume, in (mm)	48 (1219)
Tank nominal operating volume, gal (L)	1000 (3785)
Tank total volume, gal (L)	1220 (4618)
Average volume at operating depth, gal/in (L/mm)	20 (3)
Prelos Processor weight, nominal, lbs (kg)	550-640 (250-290)

Pump Vault

The Prelos 1000 Processor's patent-pending pump vault is designed to be passively self-cleaning for reduced maintenance and service needs, with no need to remove the filter from the processor for cleaning.

Materials of Construction

Vault body	Polyethylene
------------	--------------

Vault Dimensions

	in. (mm)
A	18.5 (470)
B	14.56 (370)
C	52.5 (1334)
D	16.94 (430)

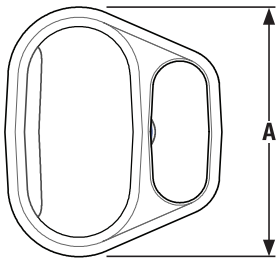

Prelos™ pump vault,
top view

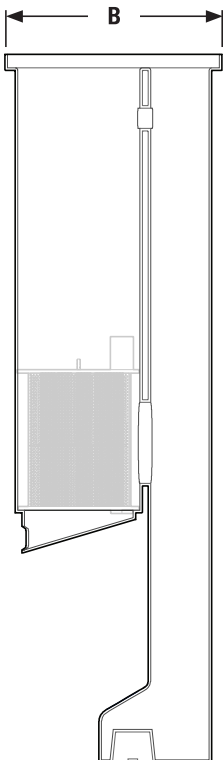

Prelos pump vault,
side-cutaway view

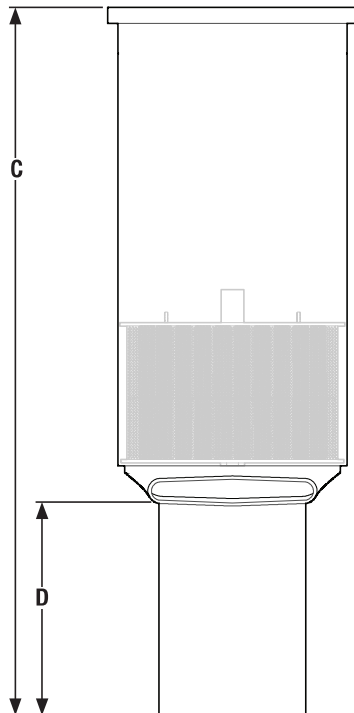

Prelos pump vault,
front view

Biotube® Filter

The Prelos 1000 Processor's Biotube® filter is designed for effective filtration of effluent and passive self-cleaning for long cleaning intervals.

Materials of Construction

End plates	DCPD
Filter tubes	Polypropylene
Handle assembly	Sch. 40 PVC
Screws	Stainless steel

Dimensions

	in. (mm)
A	16.31 (414)
B	10.0 (254)

Performance

Biotube® mesh opening, in. (mm)*	0.125 (3)
Total filter flow area, ft ² (m ²)	3.75 (0.35)
Total filter surface area, ft ² (m ²)	13.5 (1.25)

*0.062-in. (1.6-mm) filter mesh available

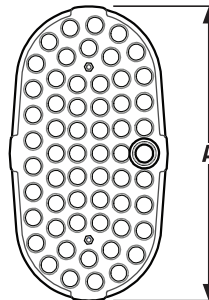

Biotube® filter
cartridge, top view

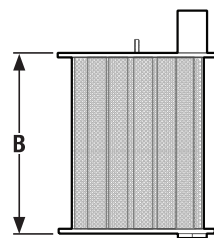

Biotube filter
cartridge, side view

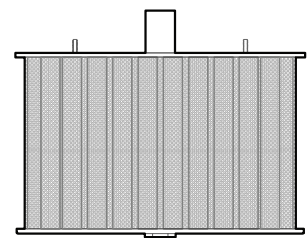

Biotube filter
cartridge, front view

4-in. (100-mm) Effluent Pump

Prelos 1000 Processors use Orenco's PF-Series 4-in. (100-mm) effluent pumps. They're field-serviceable with common tools and have a minimum 24-hour run-dry capability (liquid end) with no deterioration in pump life or performance, in internal testing. These pumps are equipped with Type SOOW 600-V power cords (suitable for Class I, Division 1 and 2 applications); they also meet UL requirements and are CSA-certified to U.S. and Canadian safety standards for effluent pumps.

Materials of Construction

Connector	Glass-filled thermoplastic, silicone
Diffusers	Glass-filled PPO
Discharge	Glass-filled polypropylene
Discharge bearing	Engineered thermoplastic (PEEK)
Impellers	Acetal
Intake screens	Polypropylene
Lubricant	Deionized water, propylene glycol
Suction connection, drive shaft, coupling, shell	Stainless steel

Specifications

Nom. flow, gpm (L/sec)	Length, in. (mm)	Weight, lb (kg)	Discharge in., nominal ¹	Impellers
10 (0.6)	23 (584)	26 (12)	1.25	6

Performance

hp (kW)	Design flow amps	Rated cycles/day	Min liquid level, in. (mm) ²
0.5 (0.37)	12.7	300	16 (406)

¹ Consult your Orenco Distributor about fittings to connect discharge assemblies to metric-sized piping.

² Minimum liquid level is for a single pump installed in a pump vault.

Pump Curve

This graph gives a representation of the pump's performance range and the relationship between flow (gpm or L/sec) and pressure (TDH).

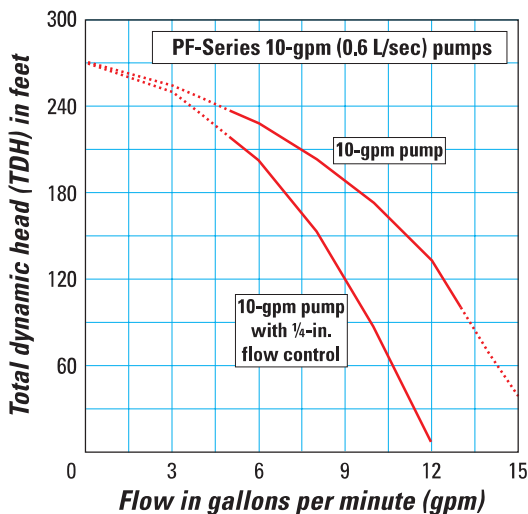

PF-Series 10-gpm pump curve

Discharge Assembly

Prelos 1000 Processors use Orenco's HDA-Series discharge assemblies for durability and ease of maintenance.

Materials of Construction

Anti-siphon valve	Sch. 80 PVC, EPDM, stainless steel
Discharge nipple	Sch. 80 PVC
Flexible hose	Reinforced EPDM
Flow control disc	Sch. 80 PVC
Hose fittings, tee fitting, mounting screws	Stainless steel
In-line check valve	Sch. 80 PVC, EPDM, stainless steel
Mounting plate	ABS
Quick-disconnect	Glass-filled thermoplastic

Working Pressures and Dimensions

Unit working pressure, psi (kPa)	150 (1034)
Height, mounting plate, in. (mm)	7 (178)
Width, mounting plate, in. (mm)	7 (178)
Diameter, discharge nipple, in. (mm)	1.25 (32)
Diameter, flow control disc orifice, in. (mm)	0.25 (6.35)

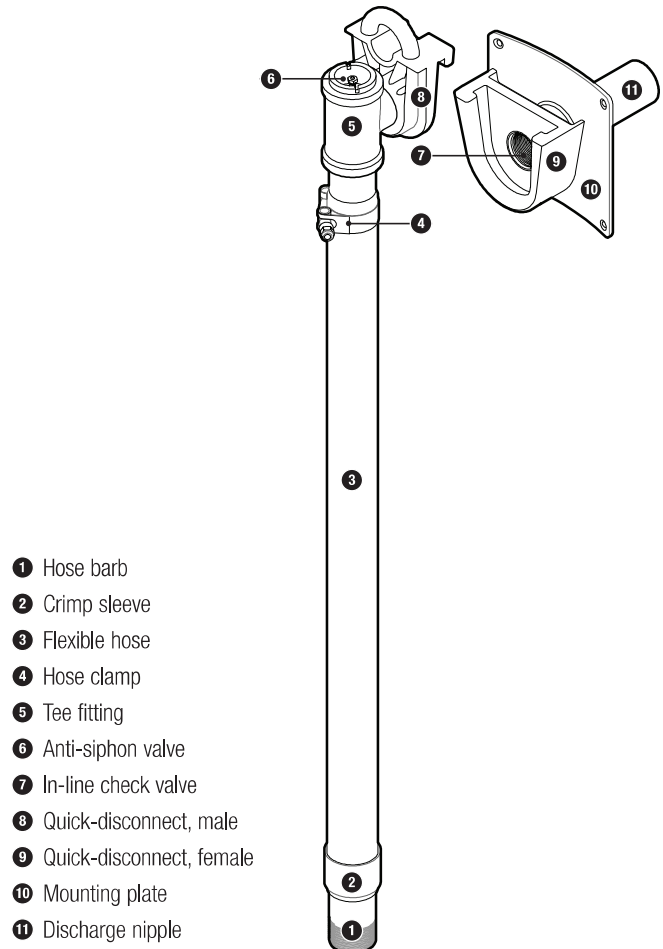

- 1 Hose barb
- 2 Crimp sleeve
- 3 Flexible hose
- 4 Hose clamp
- 5 Tee fitting
- 6 Anti-siphon valve
- 7 In-line check valve
- 8 Quick-disconnect, male
- 9 Quick-disconnect, female
- 10 Mounting plate
- 11 Discharge nipple

Discharge assembly – HDA-series

Float Switches

Float switches used in Prelos 1000 Processors are UL-listed and CSA-certified for use in water or sewage.

To simplify accessing and servicing, the float switch assembly has been incorporated into the Biotube® filter handle.

Materials of Construction

ClickTight connector	Glass-filled thermoplastic, silicone
Float collar	ABS
Float cord	Flexible 2-conductor (UL, CSA) SJOW; CPE cord jacket with EPDM insulated conductors
Float housing	Impact-resistant, noncorrosive polypropylene for use in liquids up to 140° F (60° C)

Float Switch Specifications

Float	State	Type
P	Normally open	Mechanical

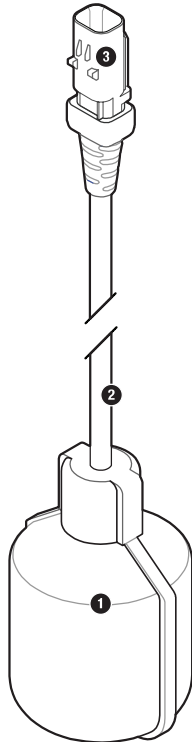
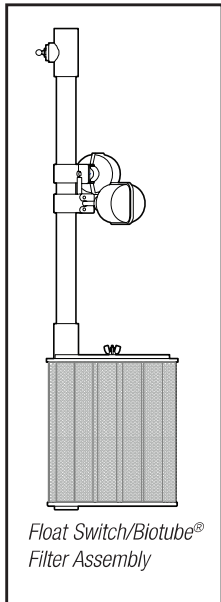

- ① Float switch
- ② Float switch cord
- ③ Float switch connector

ClickTight™ mechanical float switch

ClickTight™

Orenco's ClickTight™ provides secure, moisture-resistant cable connections between the pump, float switches, and control panel in the Prelos 1000 Processor. ClickTight is UL-listed for the US and Canada.

Materials of Construction

Cable	PVC/nylon, annealed copper; Type TC
Connectors	Glass-filled thermoplastic, silicone
Fastener	Stainless steel
Housing	ABS
O-ring	Buna N
Potting compound	Urethane

Specifications

Cable rating	14 AWG; 3-conductor; UL TC-ER 600V (Pump) 18 AWG; 2-8 conductor; UL TC-ER 600V (Float)
Float switch connectors	2-pole
Pump connector	3-pole
Maximum cable length, ft (m)	62 (19)

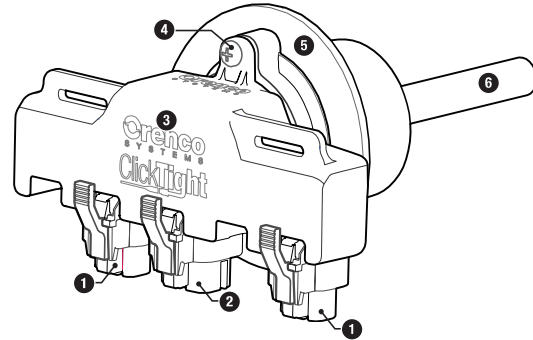

- ① Float input connector
- ② Pump input connector
- ③ ClickTight housing
- ④ Stainless steel fastener
- ⑤ Mounting flange
- ⑥ Cable

ClickTight™

S1HR Control Panel

The Prelos 1000 Processor uses Orenco's S1HR control panel, which is ideal for Prelos Sewers and other effluent sewer applications.

Materials of Construction

Enclosure	UV-resistant fiberglass, UL Type 4X
Hinges	Stainless steel

Dimensions, in. (mm)

Height	11.5 (292)
Width	9.3 (236)
Depth	5.4 (135)

Specifications

Panel ratings	120 VAC, 1 hp (0.75 kW), 16 A, 1-phase, 60 Hz
1. Motor-start contactor	16 FLA, 1 hp (0.75 kW), 60 Hz; 2.5 million cycles at FLA
2. Circuit breakers	120 VAC, 10 A, single-pole, control 120 VAC, 20 A, single-pole, pump
3. Toggle switch	Single-pole, double-throw HOA switch
4. Audio alarm	95 dB at 24 in. (600 mm), warble-tone sound, UL Type 4X 6
5. Redundant high-on relay	120 VAC, DIN rail mounted; provides a secondary pump-on signal during high-level conditions
6. Audio alarm silence relay	120 VAC, automatic reset, DIN rail mount
7. Visual alarm	$\frac{7}{8}$ -in. (22-mm) diameter red lens, "push-to-silence," 120 VAC LED, UL Type 4X

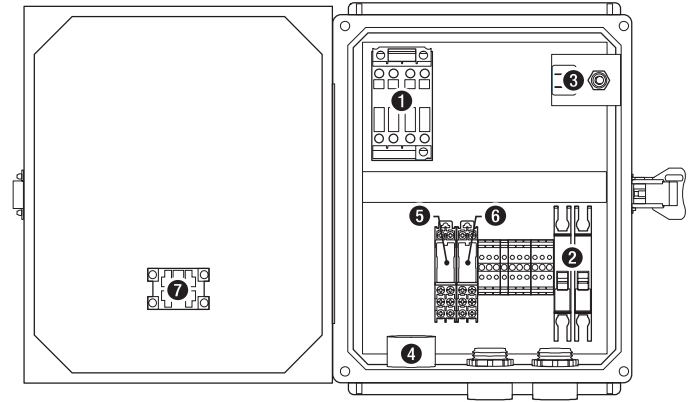

- ❶ Motor-start contactor
- ❷ Circuit breakers
- ❸ Toggle switch
- ❹ Audio alarm
- ❺ Redundant high-on relay
- ❻ Audio alarm silence relay
- ❼ Visual alarm

S1HR control panel

PVP-Series Biotube® Pump Vaults

Applications

Orenco's patent-pending PVP-Series Biotube Pump Vaults are for use with Orenco 4in (100mm) submersible effluent pumps. PVP-Series pump vaults are ideal for all types of wastewater treatment systems, such as liquid-only sewers and on-site treatment systems. These vaults house one or two Orenco high-head effluent pumps and can be used in single-compartment septic tanks with flows up to 40gpm (2.5L/sec). For flows exceeding this rate, a double-compartment septic tank or separate dosing tank is recommended.



PVP-Series Pump Vault, cross-sectional side view

General

The Orenco PVP-Series Biotube Pump Vault includes a molded polyethylene housing and an internal Biotube filter cartridge constructed of polypropylene and PVC. The pump vault keeps sludge and scum away from the filter, pump, and float switches, while the filter removes particles 1/8in (3.2mm) or larger from the tank's clear zone. This reduces suspended solids by two-thirds, on average, and allows clear effluent to be discharged.* The passively self-cleaning design extends maintenance cycle intervals. The filter cartridge can be removed without pulling the pump or the vault. PVP-series vaults can accommodate one or two high-head effluent pumps.

* [Filter Facts](#), Orenco Product Fact Sheet.

Product Code Diagram

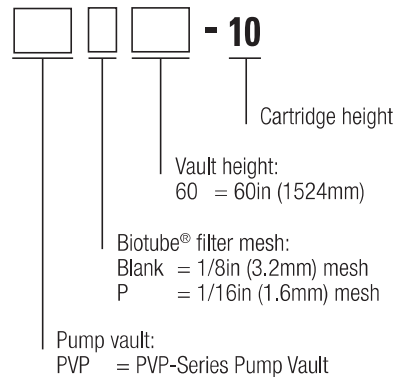

Tank Access and Riser Diameters

Diameter, in (mm)	PVP with simplex pump	PVP with duplex pumps
Tank access, minimum	18 (457)	18 (457)
Tank access, maximum	20 (508)	24 (600) [†]
Riser, minimum	24 (600)	30 (750)

[†]An extension kit, product code PVP-AEK, is required for tank access openings larger than 19in (483mm) in 30in (750mm) risers.

All product and performance assertions are based on proper design, installation, operation, and maintenance according to Orenco's current published documentation.

Pump Vault

Orenco's patent-pending PVP-Series Biotube Pump Vault is designed to be passively self-cleaning for reduced maintenance and service needs.

Materials of Construction

Vault body	Polyethylene
------------	--------------

Dimensions, in (mm)

A.	22 (559)
B.	16.63 (422)
C.	60 (1524)
D. Inlet height	10.88 (276)
E. Lowest float switch setting point	31 (787)
F.	2 (51)

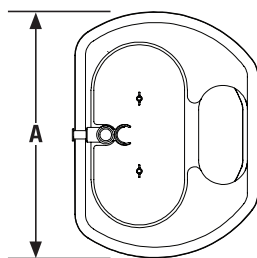

PVP-series pump vault, top view

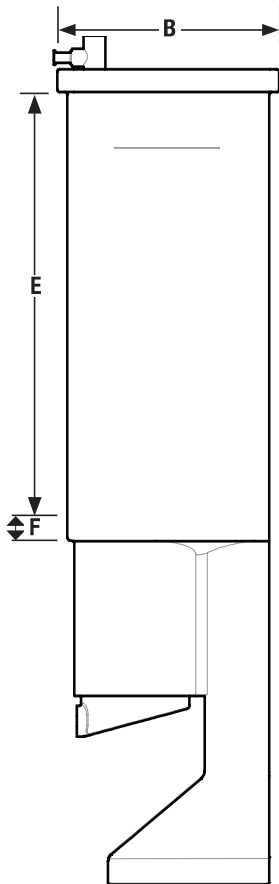

PVP-series pump vault, side view

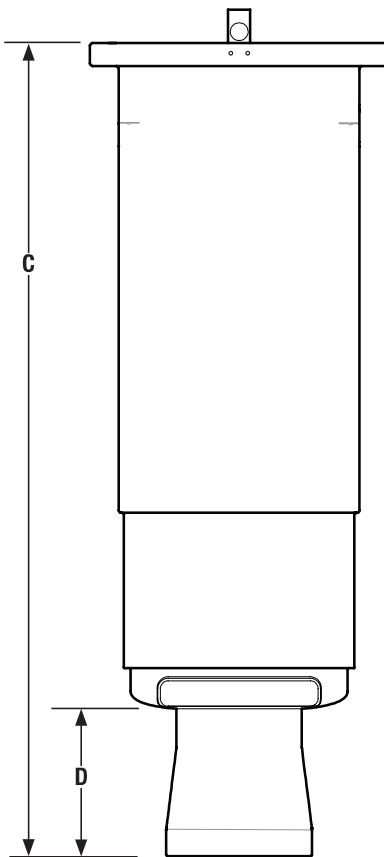

PVP-series pump vault, front view

Biotube Filter

The Orenco PVP-Series Biotube filter is designed for effective filtration of effluent and passive self-cleaning for long cleaning intervals.

Materials of Construction

End plates	DCPD
Filter tubes	Polypropylene
Handle assembly	Sch. 40 PVC
Screws	Stainless steel

Dimensions, in (mm)

A.	16.50 (419)
B.	10 (254)

Performance

Biotube mesh, in (mm)*	0.125 (3)
Total filter flow area, ft ² (m ²)	4 (0.37)
Total filter surface area, ft ² (m ²)	14 (1.3)

*0.062in (1.6mm) filter mesh available

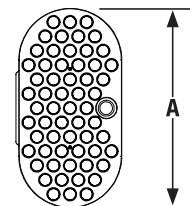

Biotube filter cartridge, top view

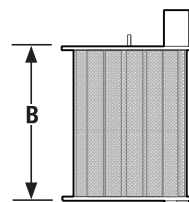

Biotube filter cartridge, side view

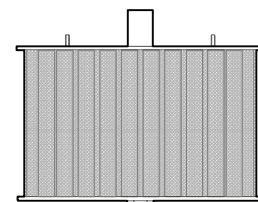

Biotube filter cartridge, front view

Pump Vault Adapter Extension Kit

The Orenco PVP-Series Biotube Pump Vault Adapter Extension Kit is required when using a 30in (750mm) riser with an access opening larger than 19in (483mm). The kit contains 2 brackets, 6 nuts, and 6 bolts.

Materials of Construction

Support brackets	Fiberglass reinforced polymer
Nuts and bolts	Stainless steel

Dimensions, in (mm)

A.	14 (356)
B.	6.5 (165)
C.	5.5 (127)
D.	27.9 (709)

Product Code Diagram

PVP - AEK

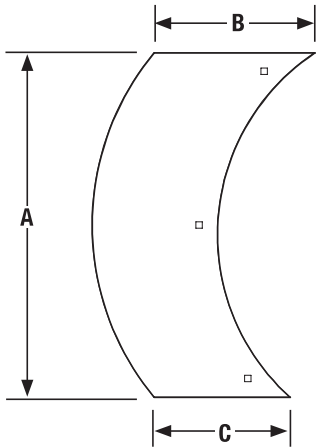

Single bracket from adapter kit

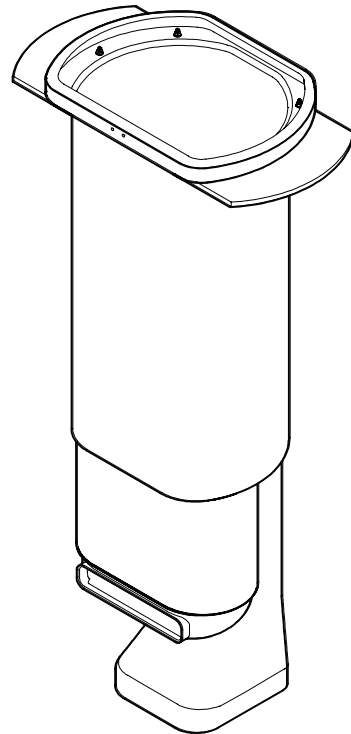

Adapter kit installed, isometric view

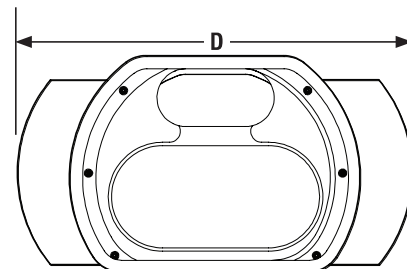

Adapter kit installed, top view

ClickTight™ Products

Applications

Orenco® ClickTight™ products provide secure, moisture-resistant cable connections between a ClickTight, a ClickTight-compatible pump, up to four ClickTight-compatible float switches, and a control panel. They eliminate the need for splice boxes, field-spliced wires, wire nuts, and conduit seals.

ClickTight is UL-listed for the US and Canada. ClickTight connectors are IP67 rated.

General

Orenco's ClickTight products greatly reduce the risk of electrical failures in wastewater systems due to moisture, faulty splices, improperly installed waterproof wire nuts, or corrosion. Two to four float switches and a pump are quickly and securely connected to the ClickTight, without the use of tools. An integral cable runs from the ClickTight to the control panel.

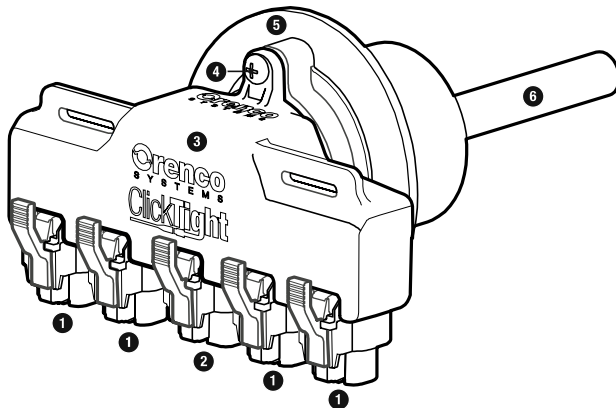

- 1 Float switch plugs, female
- 2 Pump plug, female
- 3 ClickTight™ connector
- 4 Stainless steel fastener
- 5 ClickTight coupler
- 6 ClickTight cable

ClickTight™

ClickTight™

Orenco's ClickTight greatly reduces the risk of electrical failures in onsite wastewater systems. It provides secure, water-resistant cable connections between a control panel, up to four ClickTight-compatible float switches, and a pump. It eliminates the need for splice boxes, field-spliced wires, wire nuts, and conduit seals.

ClickTight installs easily in an access riser, where it fits close to the riser wall to provide clearance for O&M activities. The ClickTight is fully potted and sealed to prevent moisture and corrosive gas from reaching the control panel.

Plug caps (product code CLK-CAP) are available for unused float switch plugs.

Materials of Construction

Cable	PVC/nylon, annealed copper
Connector housing	ABS
Coupler housing	ABS
Fastener	Stainless steel
O-ring	Buna N
Connectors	Glass-filled thermoplastic, silicone
Potting compound	Urethane

Specifications

Cable	14 AWG; 3-conductor; UL TC-ER 600V (pump) 18 AWG; 2-8 conductor; UL TC-ER 600V (float)
Cable length, maximum, ft (m)	62 (19)
Float switch connectors	2-pole, IP67
Pump connector	3-pole, IP67

Standard Models

CLK2-60, CLK3-60, CLK4-60

Product Code Diagram

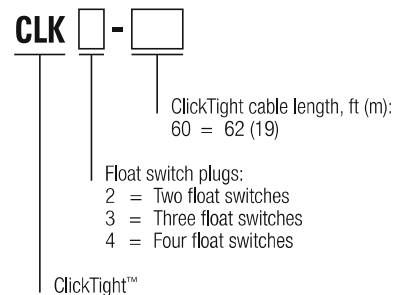

ClickTight Float Switches

ClickTight “B,” “C,” “N,” and “P” float switches are mechanical, non-mercury switches that are cUL-listed and CSA-certified for use in water or sewage. ClickTight “G” float switches are mercury switches.

Materials of Construction

Float switch collar	ABS
Float switch cord	Flexible, 2-conductor (UL, CSA) SJOW; water-resistant CPE cord jacket with EPDM insulated conductors
Float switch housing	Impact-resistant, noncorrosive polypropylene for use in liquids up to 140° F (60° C)
Float switch plug, male	Glass-filled thermoplastic, silicone, IP67

Float Switch Specifications

Float	State	Type
B	Normally open	Mechanical
C	Normally open	Mechanical
N	Normally closed	Mechanical
P	Normally open	Mechanical
G	Normally open	Mercury

Standard Models

B, C, N, P, G

Product Code Diagram

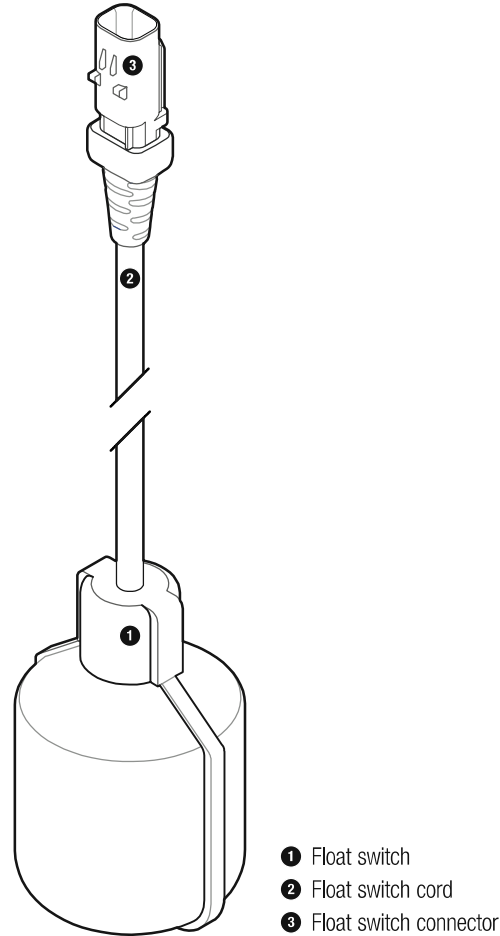
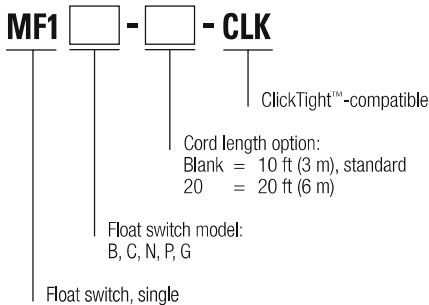

ClickTight float switch (mechanical float switch shown)

ClickTight™ Pump Cord Adapters

Orenco's ClickTight™ pump cord adapters provide a means of retrofitting a ClickTight pump connector to an existing Orenco pump or a customer-sourced, single-phase, 120V/240V pump of up to 1 hp (0.75 kW) and rating of 13 FLA.

Materials of Construction

Connector	Glass-filled thermoplastic, silicone
Heat shrink	Adhesive-filled polyolefin
Splice connector	Nylon, copper

Specifications

Pump adapter cord	3-conductor, 16 AWG, SOOW, 600V
Pump adapter cord plug, male	3-pole, IP67
Heat shrink	12-6 AWG, 600V
Splice connector	16-14 AWG

Product Code Diagram

CLK - PA

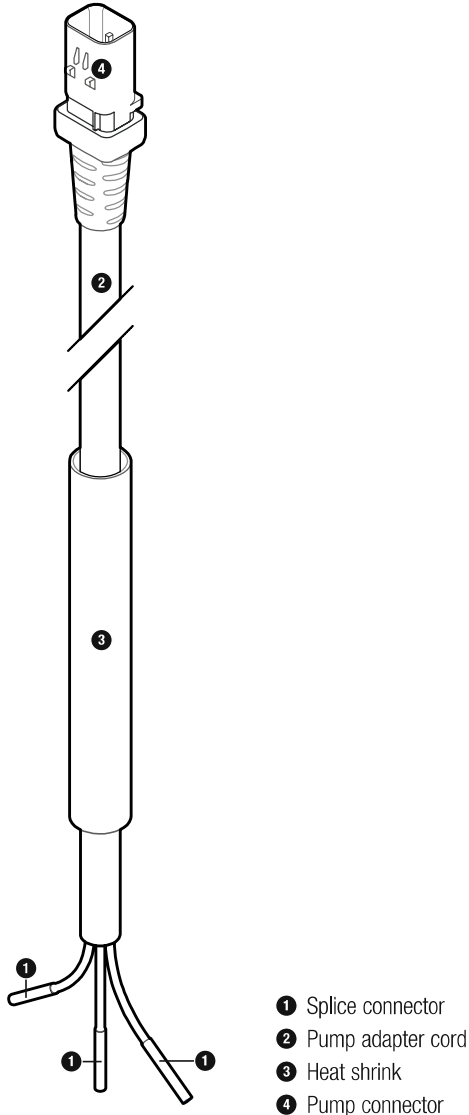
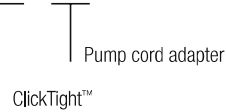

ClickTight pump cord adapter

ClickTight-Compatible Effluent Pumps

Orenco's ClickTight-compatible PF-Series 4-in. (100-mm) effluent pumps* are the fast and simple way to add pumping capability to the ClickTight Controls Package. They're field-serviceable with common tools and have a minimum 24-hour run-dry capability (liquid end) with no deterioration in pump life or performance, in internal testing.

* For PF-Series effluent pumps, see Orenco Tech Data Sheet NTD-PU-PF-1.
PVA-series pumps are also available. See Orenco Tech Data Sheet NTD-PU-PVA-1 for details.

Materials of Construction

Connector	Glass-filled thermoplastic, silicone, IP67
Diffusers	Glass-filled PPO
Discharge	Glass-filled polypropylene
Discharge bearing	Engineered thermoplastic (PEEK)
Impellers	Acetal
Intake screens	Polypropylene
Lubricant	Deionized water, propylene glycol
Suction connection, drive shaft, coupling, shell	Stainless steel

Standard Models

PF100511-CLK, PF100511CV-CLK, PF100512-CLK, PF100712-CLK,
PF200511-CLK, PF200512-CLK, PF300511-CLK, PF300512-CLK,
PF300712-CLK, PF500511-CLK, PF500512-CLK, PF500712-CLK,
PVA100511-CLK, PVA300511-CLK, PVA500511-CLK

Product Code Diagram

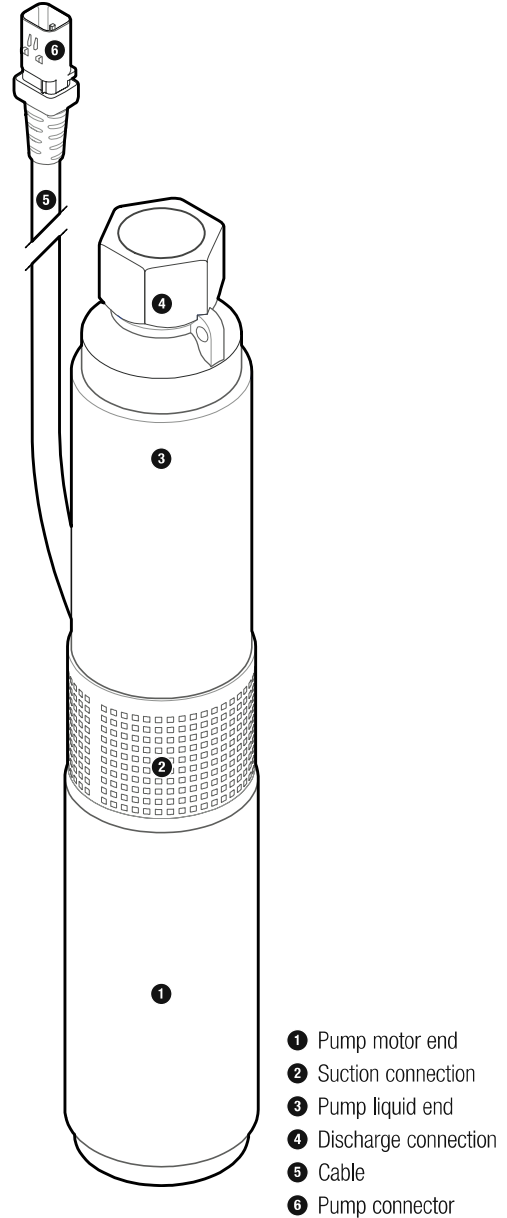
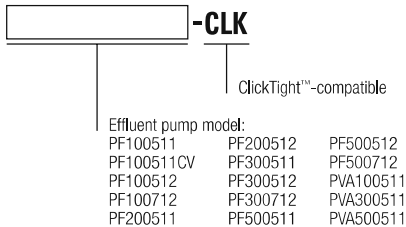

ClickTight-compatible effluent pump

HDA Discharge Assemblies

Applications

Orenco's HDA Discharge Assemblies are designed to work with 4-inch (100-mm) submersible effluent pumps to convey effluent to the exterior of a riser, tank or basin. They are not intended for "low-head" centrifugal pumps. HDA discharge assemblies are suitable for most pumping applications requiring simplex or duplex pumps. And they are ideal for sites with deep burial needs or cold weather conditions.

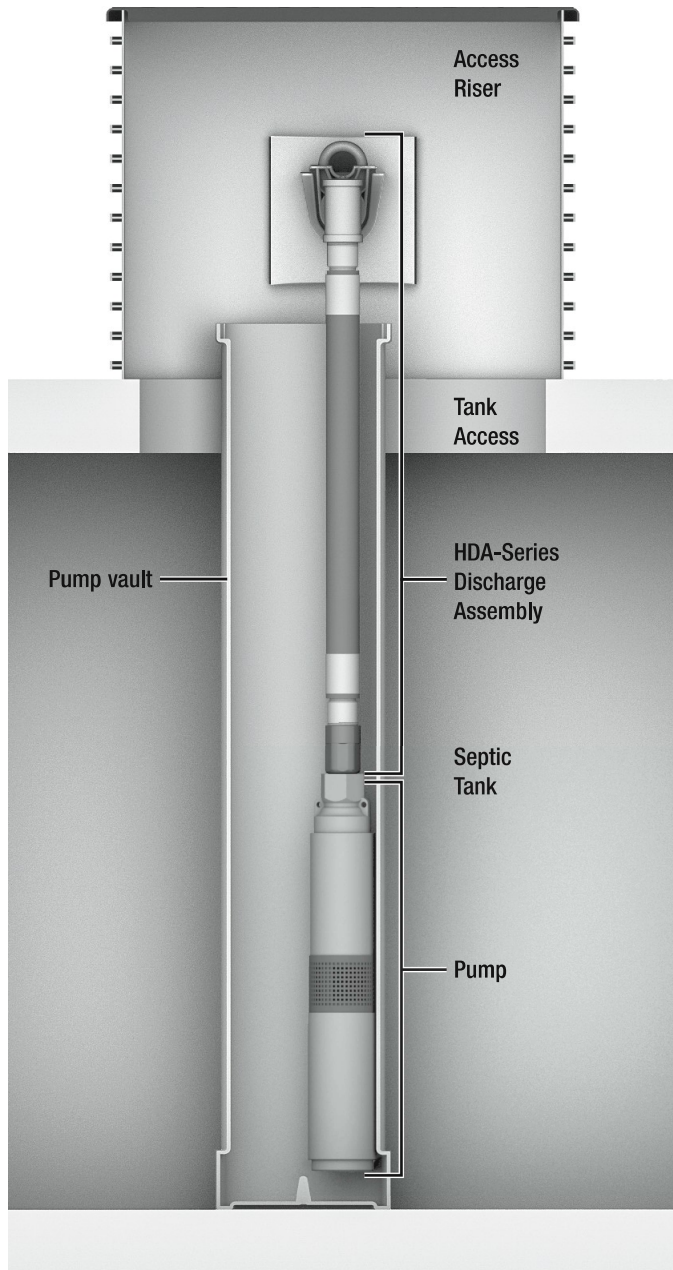

HDA Discharge Assemblies provide clear access to tank and basin components. (Cross-sectional illustration of simplex HDA installed in a typical concrete tank.)

General

HDAs are hanging-style discharge assemblies designed to provide a simple, durable, watertight installation and clear access to tank and basin components. They combine an ABS mounting plate with a quick-disconnect fitting and a section of flexible, high-pressure hose with stainless steel fittings. Hose length is determined by the system configuration. Contact your Distributor or Orenco for more information.

HDAs are rated for 10-, 20-, and 30-gpm pumps (0.6-, 1.3-, and 1.9-L/sec). They are extremely easy to remove and reinstall for servicing with a simple tool (HDATool), available separately for purchase.

Standard Models

HDAS24125CFCASLC-XX

HDAD24125CFCASLC-XX

HDATool

Product Code Diagram

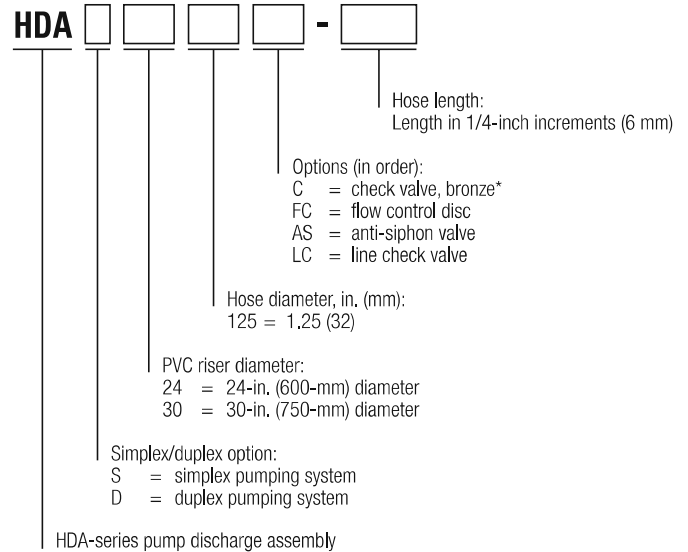

* Bronze check valves are not needed if the pump used has an internal check valve. Orenco's PF100511CV pump is equipped with an internal check valve.

Materials of Construction

HDA

Anti-siphon valve	Sch. 80 PVC, EPDM, stainless steel
Check valve	Bronze
Crimp sleeve	Stainless steel
Discharge nipple	Sch. 80 PVC
Flexible hose	Reinforced EPDM
Flow control disc	Sch. 80 PVC, 1/8-inch (3.2 mm) orifice
Hose barb	Stainless steel
Line check valve	Sch. 80 PVC, EPDM, stainless steel
Mounting plate	ABS (simplex), fiberglass (duplex)
Mounting plate screws	Stainless steel
Quick-disconnect	Glass-filled thermoplastic
Tee fitting	Stainless steel

HDATOOL

Handle	Fiberglass
Tool head	Stainless steel
End cap	Rubber

Working Pressures and Dimensions

Model	HDAS24125C-XX	HDAD24125C-XX
Unit working pressure, psi (kPa)	150 (1034)	150 (1034)
Height, mounting plate, in. (mm)	7 (178)	7 (178)
Width, mounting plate, in. (mm)	7 (178)	14 (356)
Diameter, discharge nipple, in. (mm)	1¼ (32)	1¼ (32)
Diameter, flow control disc orifice, in. (mm)	¼ (6.35)	¼ (6.35)

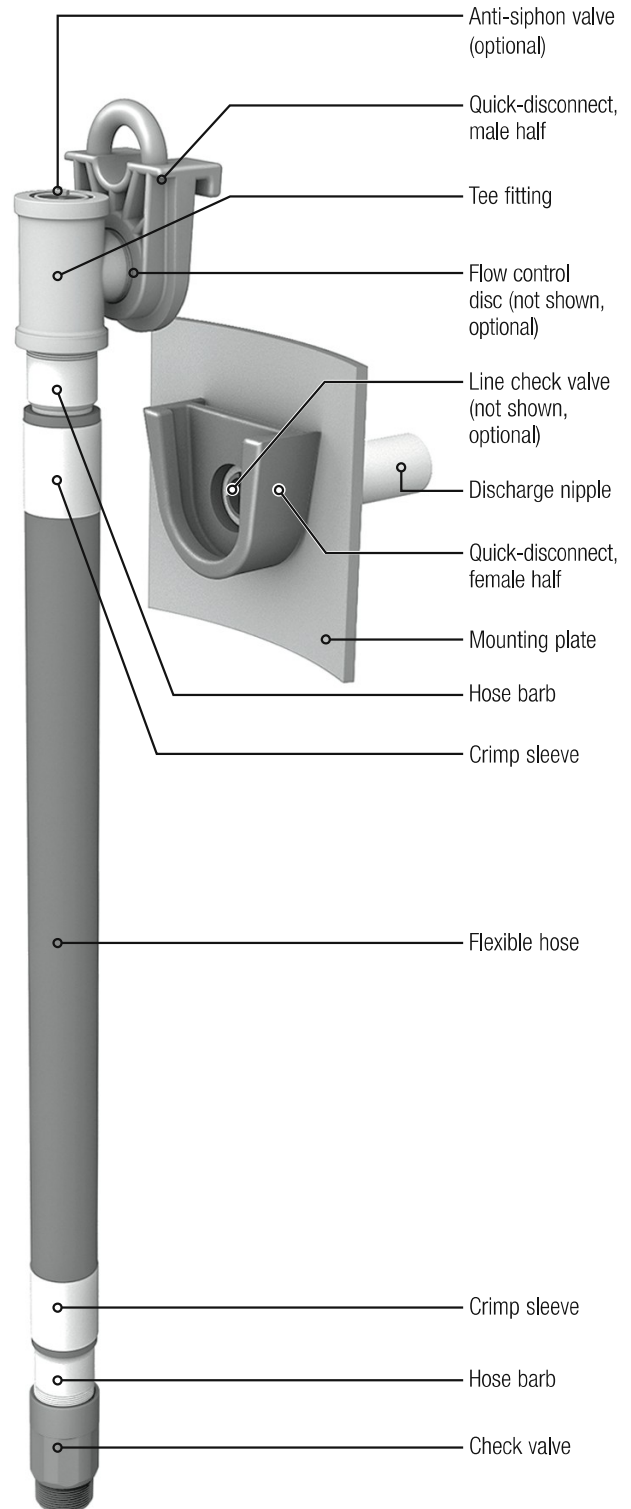

HDA Discharge Assemblies are constructed of durable, corrosion-resistant parts that are designed to work together for a long service life. (Simplex model shown.)

Hose Length Selection Chart

Correct HDA Hose Length for Pump and PVU Model, in. (mm)*							
Pump	PVU48	PVU57	PVU68	PVU72	PVU84	PVU95	PV55
PF100511CV ²	24.00 (610)	33.00 (838)	44.00 (1118)	48.00 (1219)	60.00 (1524)	71.00 (1803)	31.75 (806)
PF10051X	21.00 (533)	30.00 (762)	41.00 (1041)	45.00 (1143)	57.00 (1448)	68.00 (1727)	27.75 (705)
PF100712	18.00 (457)	27.00 (686)	38.00 (965)	42.00 (1067)	54.00 (1372)	65.00 (1651)	24.75 (629)
PF15031X	24.50 (622)	33.50 (851)	44.50 (1130)	48.50 (1232)	60.50 (1537)	71.50 (1816)	31.25 (794)
PF20051X	21.75 (552)	30.75 (781)	41.75 (1060)	45.75 (1162)	57.75 (1467)	68.75 (1746)	28.50 (724)
PF201012	15.50 (394)	24.50 (622)	35.50 (902)	39.50 (1003)	51.50 (1308)	62.50 (1588)	22.25 (565)
PF201512	10.00 (254)	19.00 (483)	30.00 (762)	34.00 (864)	46.00 (1168)	57.00 (1448)	16.75 (425)
PF30051X	22.75 (578)	31.75 (806)	42.75 (1086)	46.75 (1187)	58.75 (1492)	69.75 (1772)	29.50 (749)
PF300712	19.25 (489)	28.25 (718)	39.25 (997)	43.25 (1099)	55.25 (1403)	66.25 (1683)	26.00 (660)
PF301012	17.00 (432)	26.00 (660)	37.00 (940)	41.00 (1041)	53.00 (1346)	64.00 (1626)	23.75 (603)
PF301512	11.25 (286)	20.25 (514)	31.25 (794)	35.25 (895)	47.25 (1200)	58.25 (1480)	18.00 (457)
PVA100511	22.00 (559)	31.00 (787)	42.00 (1067)	46.00 (1168)	58.00 (1473)	69.00 (1753)	28.75 (730)
PVA300511	23.50 (597)	32.50 (826)	43.50 (1105)	47.50 (1207)	59.50 (1511)	70.50 (1791)	30.25 (768)
PF10053200	21.00 (533)	30.00 (762)	41.00 (1041)	45.00 (1143)	57.00 (1448)	68.00 (1727)	30.75 (781)
PF10073200	18.50 (470)	27.50 (699)	38.50 (978)	42.50 (1080)	54.50 (1384)	65.50 (1664)	25.25 (641)
PF20053200	21.75 (552)	30.75 (781)	41.75 (1060)	45.75 (1162)	57.75 (1467)	68.75 (1746)	28.50 (724)
PF20103200	16.25 (413)	25.25 (641)	36.25 (921)	40.25 (1022)	52.25 (1327)	63.25 (1607)	23.00 (584)
PF20153200	13.25 (337)	22.25 (565)	33.25 (845)	37.25 (946)	49.25 (1251)	60.25 (1530)	20.00 (508)
PF30053200	22.75 (578)	31.75 (806)	42.75 (1086)	46.75 (1187)	58.75 (1492)	69.75 (1772)	29.50 (749)
PF30073200	19.50 (495)	28.50 (724)	39.50 (1003)	43.50 (1105)	55.50 (1410)	66.50 (1689)	26.25 (667)
PF30103200	17.50 (445)	26.50 (673)	37.50 (953)	41.50 (1054)	53.50 (1359)	64.50 (1638)	24.25 (616)
PF30153200	14.25 (362)	23.25 (591)	34.25 (870)	38.25 (972)	50.25 (1276)	61.25 (1556)	21.00 (533)
PF301534	14.50 (368)	23.50 (597)	34.50 (876)	38.50 (978)	50.50 (1283)	61.50 (1562)	21.25 (540)

* Hose lengths shown are based on a discharge hole center height of 8 inches (200 mm) from the bottom of the riser and with the pump vault's support pipes resting on the top of the tank. These lengths also work for a discharge hole center height 11 inches (279 mm) from the bottom of the riser when using an Orenco RRFTA24 or FRFTA24-RVF tank adapter on a tank. Other factors may affect the hose length selection process. Contact Orenco for more details.

Orenco DuraFiber™ FLD Access Lids

Applications

Orenco DuraFiber FLD Access Lids provide secure, durable, watertight coverings for ribbed PVC, HDPE, and Orenco FRP risers, pump basins, and access ports. They are capable of supporting a 2500lb (1134kg) load; however, they are not recommended for vehicular traffic.

FLD24 24in (600mm) lids require an RLA24 adapter to connect to Perma-Loc™ pipe. FLD30 30in (750mm) lids are not compatible with RLA30 Riser-Lid-Adapters or 30in (750mm) Perma-Loc pipe.

General

DuraFiber FLD lids are designed for extreme durability and damage resistance, with UV- and corrosion-resistant materials, optional EPDM gaskets for watertight lid-to-riser connections, and flat-style flanges for easy access with clean, flush-to-grade installations. They also have centering rings for easy alignment. FLD lids feature a non-skid surface and a molded-in caution statement, with room for a customer logo. All come with four 5/16in stainless steel socket cap screws and a hex key wrench.

FLD lids are available with optional insulation, installed at the factory or in kits that can be installed in the field.

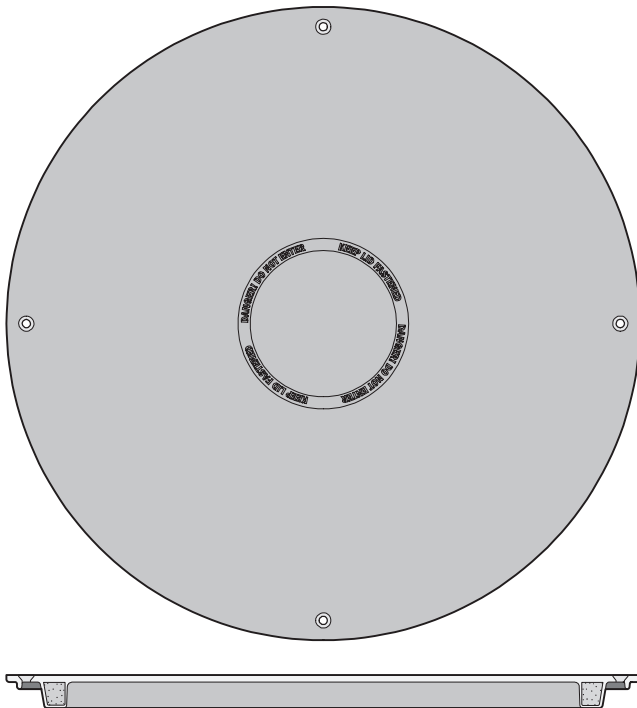

DuraFiber FLD lid: top view and side-cutaway view

Standard Models

FLD18G, FLD24G, FLD24G-ATX, FLD24G-W, FLD30G, FLD30G-ATX, FLD30G-PRELOS, FLD30G-W

Product Code Diagram

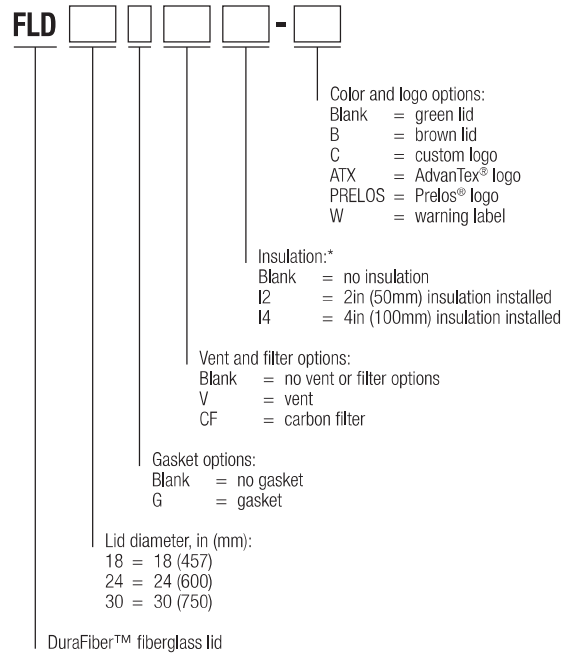

*Insulation has an R-value of 10 per 2in (RSI of 1.8 per 50mm) increment

Materials of Construction

Lid	Fiber-reinforced polymer (FRP)
Gasket (FLD18)	Urethane
Gasket (FLD24, FLD30)	EPDM
Centering ring core	Structural foam
Mounting hardware	Stainless steel
Insulation, optional	Closed-cell foam
Insulation mounting hardware	Stainless steel

Specifications

Model	FLD18XX	FLD24XX	FLD30XX
A in (mm)	20.2 (514)	25.75 (654)	32.75 (832)
B in (mm)	1.5 (38)	1.5 (38)	1.5 (38)
C in (mm)	17.5 (445)	23.25 (591)	29.25 (743)
Insulation R-value per 2in (RSI per 50mm) increment	10 (1.8)	10 (1.8)	10 (1.8)
Gasket width, in (mm)	0.75 (19)	0.69 (18)	0.69 (18)
Bolt hole diameter, in (mm)	0.3125 (8)	0.3125 (8)	0.3125 (8)
Weight, lbs (kg)	7 (3)	11 (5)	20 (9)
Bolt holes per lid	4	4	4

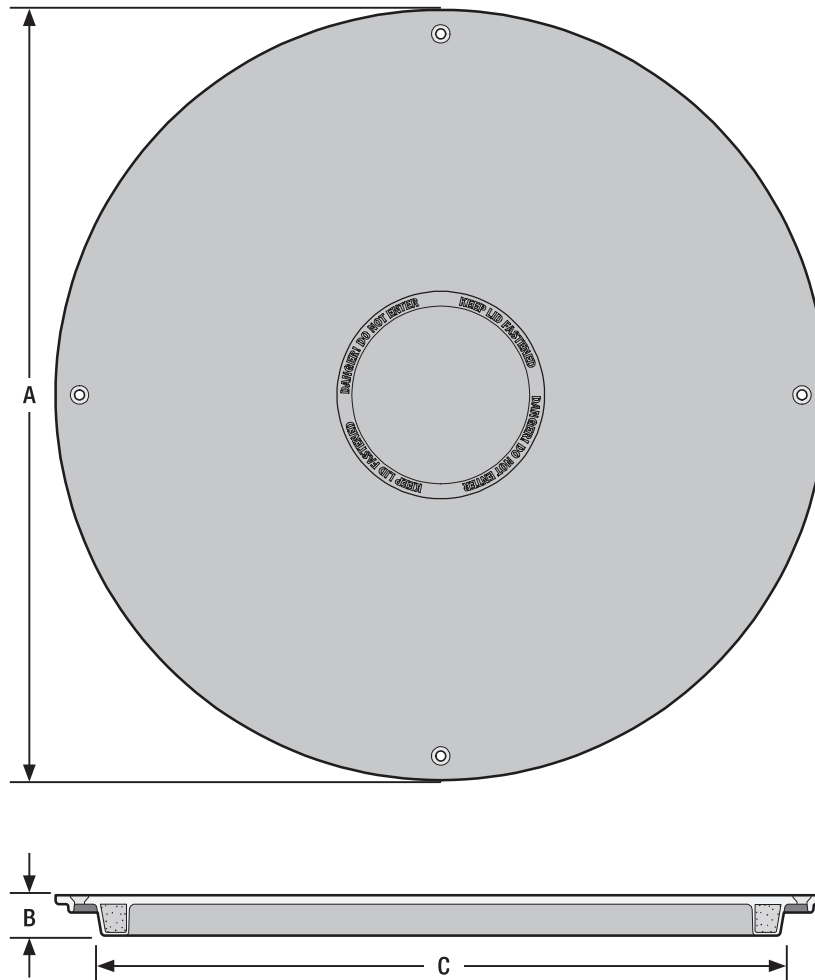

FRP Access Risers

Applications

Orenco FRP (fiberglass-reinforced polymer) Access Risers are designed to provide access to septic tank openings, as well as watertight connections between the tank, riser, and lid. They can be cast into the tops of concrete tanks or bonded to a fiberglass or dicyclopentadiene (DCPD) tank. Orenco FRP Access Risers can also be used as valve enclosures.

The RF24 and RF30 FRP access risers are designed for use with Orenco's FLD access lid.

General

Orenco FRP Access Risers are constructed of filament-wound fiberglass to be lightweight, corrosion resistant, and extremely strong. Risers are available in 24in and 30in (600mm and 750mm) diameters, with heights available in 3in (75mm) increments. They have four bolt catches to secure access riser lids and are compatible with Orenco tank adapters. See <https://www.orencowater.com/products/gravity-pump-products/access-risers/riser-tank-adapters> for information on adapters.



Orenco FRP Access Risers are available in 24in and 30in (600mm and 750mm) diameters.

Riser Wall Thickness

Length	RF24XX	RF30XX
Up to 8ft (2.4m)	0.1875in (5mm)	0.25in (6mm)
8ft (2.4m) - 12ft (3.7m)	0.3125in (8mm)	0.3125in (8mm)
Over 12ft	Custom	Custom

Standard Models

RF24XX, RF30XX

Product Code Diagram

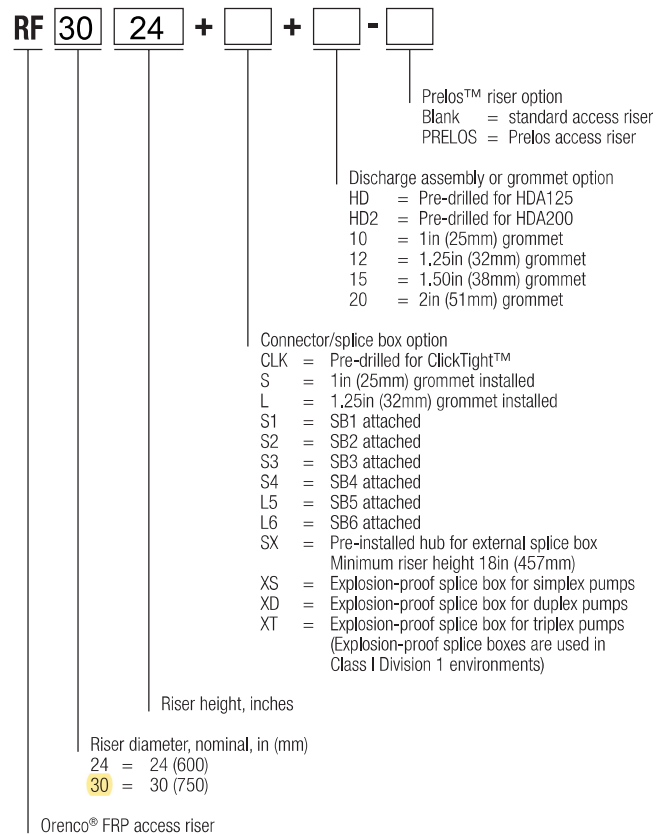

Materials of Construction

Access riser	Fiberglass-reinforced polymer
Bolt catches	Glass-filled nylon
Hardware	Stainless steel

Specifications

Model	RFP24	RFP30
Inside diameter, in (mm)	23.5 (597)	29.5 (749)
Outside diameter, in (mm)	24 (600)	30 (750)
Weight, lb/ft (kg/m)	11 (16)	18 (27)

S-Series Simplex Control Panels

Applications

Orengo® S-Series Simplex Control Panels control single pumps in effluent sewer (STEP) systems, onsite septic systems, and for pump control into conventional gravity sewer systems.



Orengo S-Series Simplex Control Panel (S1ETMCT shown)

Materials of Construction

Component	Material
Enclosure	UV-resistant fiberglass, Type 4X (IP 66)
Hinge	Stainless steel
Latch	Stainless steel

Specifications

Feature	Specifications
Height, in. (mm)	11.5 (292)
Width, in. (mm)	9.3 (236)
Depth, in. (mm)	5.4 (137)
S1 panel ratings*	120 VAC, 1 hp (0.75 kW), 16 A, 1-phase, 60 Hz
S2 panel ratings*	240 VAC, 3 hp (2.24 kW) 16 A, 1-phase, 60 Hz

* Pump motors used with these panels require internal overload protection.

General

Orengo® S-Series Simplex Control Panels are electro-mechanical panels for controlling single pumps. Standard features include an Automatic/Off/Manual (Auto/Off/Man) toggle switch, controls circuit breaker, pump circuit breaker, automatic motor control operation, and an audible/visible high water level alarm with auto reset. Specifications for standard and optional features are listed on page 2.

All S-Series control panels have a 120 VAC controls circuit breaker. S1 panels have a 120 VAC pump circuit breaker, while S2 panels have a 240 VAC pump circuit breaker.

All S-Series panels can be used with both mechanical and mercury float switches.

Listed per UL-508 and cUL-508; CE-listed versions of S-Series panels are available.

Standard Models

S1, S2

Nomenclature

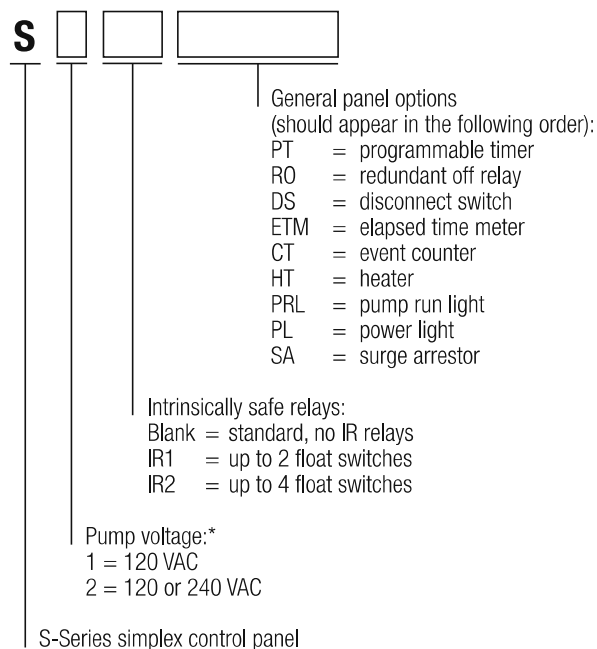

* All controls circuits require 120 VAC power

S-Series Simplex Control Panels

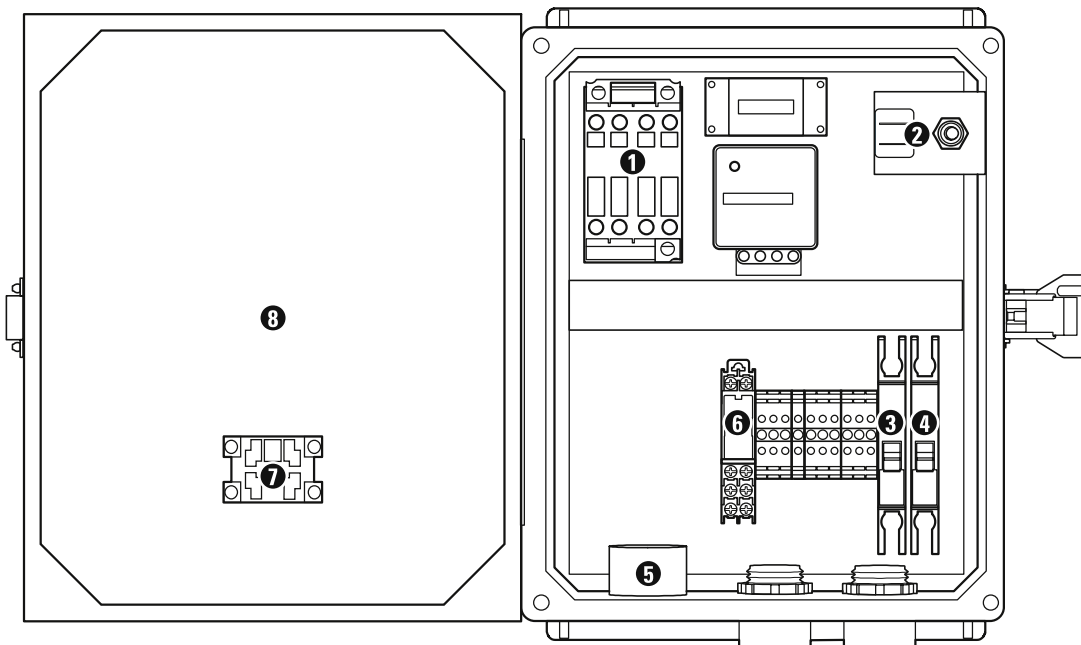

Orenco S-Series Simplex Control Panel (S1ETMCT shown)

Standard Features

Feature	Specifications (all voltages are 120 VAC unless otherwise noted)
1. Motor-start contactor	120 VAC: 17 FLA, 1 hp (0.75 kW), 2.5 million cycles at FLA 240 VAC: 17 FLA, 3 hp (2.24 kW), 2.5 million cycles at FLA
4. Auto/Off/Man toggle switch	Single-pole, double-throw HOA switch
2. Controls circuit breaker	10 A, OFF/ON switch, single pole, DIN rail mounting with thermal magnetic tripping characteristics
3. Pump circuit breaker	20 A, OFF/ON switch, single pole (120 VAC) or double pole (240 VAC), DIN rail mounting with thermal magnetic tripping characteristics
5. Audible alarm	95 dB at 24 in. (610 mm), warble-tone sound; gasketed, UL Type 4X (IP66)
6. Audible alarm silence relay	Automatic reset, DIN rail mount
7. Visible alarm	7/8-in. (22-mm) diameter red lens, "Push-to-silence," UL Type 4X (IP66), 1 W LED light
8. Enclosure	UV-resistant fiberglass and stainless steel, UL Type 4X (IP66)

Optional Features

Feature	Specifications (all voltages are 120 VAC unless otherwise noted)	Product code adder
Intrinsically safe control relays	Listed per UL 698A, for Class 1 Div. 1, groups A, B, C, D hazardous locations (Requires larger enclosure)	IR
Programmable timer	Repeat cycle from 0.05 seconds to 30 hours; separate variable controls for OFF & ON time periods	PT
Redundant off relay	DIN rail mount; provides a secondary off; sounds alarm upon low level condition	RO
Disconnect switch	120 VAC or 240 VAC; switch configuration is dependent on voltage and amperage	DS
Elapsed time meter	7-digit, non-resettable; limit of 99,999 hours; accurate to 0.01 hours	ETM
Event counter	6-digit, non-resettable	CT
Heater	anti-condensation heater; self-adjusting: radiates additional wattage as temperature drops	HT
Pump run light	7/8-in. (22-mm) diameter green lens; UL Type 4X (IP66), 1 W LED light	PRL
Power light	7/8-in. (22-mm) diameter green lens; UL Type 4X (IP66), 1 W LED light	PL
Surge arrestor	Status light on unit; protects incoming power supply from electrical surges	SA

Prelos™ Sewer

Prelos™ Processor On-Lot Package (Extended Pump)

L I M I T E D W A R R A N T Y

Commitment to Quality

Since 1981, Orenco Systems®, Incorporated (herein-after referred to as "Orenco"), has been known as a company that researches, designs, manufactures, and sells the highest-quality products. Prelos™ is the modern Pressurized Liquid-Only Sewer, a culmination of four decades of Orenco's proven community sewer solutions. At the core of the system is the Prelos Processor, a complete, integrated package that provides on-lot wastewater storage, filtration, and pumping to the pressurized liquid-only sewer.

Any wastewater system can be affected by improper design or installation, lack of maintenance, or system abuse. Although our products are carefully designed and constructed, it's still important to pay strict attention to system design and installation instructions and to follow through with intelligent usage and regular maintenance.

Limited Warranty Coverage

Subject to the exclusions, limitations, and conditions contained herein, Orenco warrants to the purchaser and subsequent owners, for a period of time corresponding to the type of product (the "Warranty Period," as listed below), that all of the component products comprising a Prelos Processor will be free from defects in materials or workmanship that cause the product to lose structural integrity or to electrically or mechanically operate improperly.

- (a) For Orenco multiple-stage, high-head, submersible turbine effluent pumps, the Warranty Period will be for ten years from the date of manufacture.
- (b) For all other component products, the Warranty Period will be for five years from the date of installation.

If Orenco determines that a Prelos Processor component has failed within the Warranty Period because of a defect in materials or workmanship, Orenco will repair or replace, at its discretion, the failed component.

Obtaining Warranty Service

To make a claim under this Limited Warranty, directly contact your Orenco Commercial and Municipal Wastewater Systems Dealer or Supplier ("Orenco's Representative"), who will process your claim. If for some reason Orenco's Representative is unavailable, or if you purchased your Prelos Processor directly from Orenco, contact Orenco by phone (800-348-9843 or +1-541-459-4449) to make your claim.

Any warranty claim must be received no later than the expiration of the Warranty Period listed above.

If requested by Orenco, potentially defective components must be returned to Orenco's Sutherlin, Oregon facility through Orenco's Representative, if applicable, transportation prepaid.



Exclusive Remedy

The exclusive remedy for any claim under this Limited Warranty shall be the obligation of Orenco to repair or exchange, at its discretion, any defective components. Except for Orenco staff time spent repairing or exchanging a defective component, any and all labor expenses associated with identifying, removing, shipping, repairing, or replacing defective components are not covered under this Limited Warranty. Defects in materials or workmanship will be determined in good faith by Orenco upon receipt and inspection of a returned component. Components shall not be deemed to be defective if the failure, malfunction, or damage was caused by, or resulted from:

- (a) the Prelos Processor not being designed properly for the application in accordance with Orenco's design criteria or not being installed in accordance with said design;
- (b) abuse, misuse, accident, or negligence;
- (c) a catastrophic event beyond the control of Orenco; or
- (d) improper or incorrectly performed installation, maintenance, repair, or modification of any component of the Prelos Processor.

In the event Orenco determines that a returned component is defective in materials or workmanship and covered by this Limited Warranty, Orenco will credit or reimburse you for all reasonable transportation charges incurred in returning the component, and will be responsible for all transportation charges to return the repaired or exchanged component to you. The Warranty period for such repaired or exchanged component shall toll from the original purchase. In the event Orenco determines that a returned component is not defective in materials or workmanship, or is not covered by this Limited Warranty, Orenco may charge you a testing fee and all reasonable transportation charges required to return the component to you.

IN EXCHANGE FOR THE WARRANTY COVERAGE, PURCHASER AND SUBSEQUENT OWNERS AGREE THAT ORENCO WILL NOT BE LIABLE FOR ANY LOSS, INJURY, OR DAMAGES TO PERSONS OR PROPERTY RESULTING FROM FAILURE OF, OR ANY DEFECT IN, THE PRELOS PROCESSOR, OR FOR ANY TECHNICAL ASSISTANCE OR INFORMATION THAT ORENCO MAY HAVE PROVIDED TO THE OWNER. NOR SHALL ORENCO BE LIABLE FOR ANY INCIDENTAL, CONSEQUENTIAL, SPECIAL, OR INDIRECT DAMAGES OF ANY KIND, INCLUDING, BUT NOT LIMITED TO, LOSS OF PROFITS, PLANT DOWNTIME, FINES OR PENALTIES, OR LAWSUITS BY THIRD PARTIES AGAINST THE PRELOS PROCESSOR OWNER OR LOT OWNER. IN NO EVENT SHALL THE LIABILITY OF ORENCO UNDER THIS LIMITED WARRANTY EXCEED THE TOTAL INVOICED PRICE, EXCLUDING INSTALLATION AND/OR STARTUP COSTS, OF THE PRELOS PROCESSOR.

Disclaimer

EXCEPT AS SPECIFIED IN THIS LIMITED WARRANTY, ALL EXPRESS OR IMPLIED CONDITIONS, REPRESENTATIONS, AND WARRANTIES INCLUDING, WITHOUT LIMITATION, ANY IMPLIED WARRANTY OR CONDITION OF MERCHANTABILITY, FITNESS FOR A PARTICULAR PURPOSE, SATISFACTORY QUALITY, ACCURACY OF INFORMATIONAL CONTENT, OR THOSE ARISING FROM A COURSE OF DEALINGS, LAW, USAGE, OR TRADE PRACTICE, MAY ONLY BE CLAIMED DURING THE WARRANTY PERIOD, AND THEREAFTER ARE HEREBY EXPRESSLY DISCLAIMED AND EXCLUDED TO THE EXTENT ALLOWED BY APPLICABLE LAW.

Exclusions and Limitations

This Limited Warranty shall be void if any of the following occur:

- (a) construction or installation of the Prelos Processor is not performed in accordance with Orenco's published *Installation Instructions*;
- (b) components not provided or approved by Orenco are used in the installation, maintenance, or repair of the Prelos Processor;
- (c) settings or operation of pumps, metering devices, effluent distribution components or other parts that can affect the integrity and proper functioning of the Prelos Processor are changed without authorization from Orenco, Orenco's Representative, or an Authorized Commercial Operator; or
- (d) the Prelos Processor is not operated or maintained in accordance with the instructions contained in the *Operation and Maintenance Manual* provided by Orenco.

Prelos1500-24A-Terrebonne

Orenco® Prelos® 1500 Processor

Applications

Orenco's Prelos 1500 Processor provides complete, integrated storage, filtration, and pumping of wastewater for on-lot portions of Prelos Sewer systems and other pressurized liquid-only sewers or dispersal systems.

General

The Prelos Processor is the core of the Prelos Sewer System: an innovative technology based on 40 years of proven sewer solutions. The tank stores and passively treats solid waste, while the patent-pending pump vault and filter separate and pump liquid effluent.*

All Prelos 1500 Processors install as a unit, to reduce errors. The standard 30in (750mm) diameter access riser and optional additional 24in (600mm) diameter access riser provide easy access to the tank interior, and the passively self-cleaning filter can be removed without removing the pump vault, pump, or discharge assembly, simplifying O&M and keeping related costs down.

* Tank covered under United States Patent #10,392,281

Selected Models

PRELOS1500-24, PRELOS1500-36, PRELOS1500-24-24, PRELOS1500-36-36

Product Code Diagram

PRELOS 1500 - -

Optional secondary access riser height, in (mm):	
Blank = no secondary riser	36 = 36 (914)
18 = 18 (457)	48 = 48 (1219)
24 = 24 (610)	60 = 60 (1524)
30 = 30 (762)	
Access riser height, in (mm):	
18 = 18 (457)	36 = 36 (914)
24 = 24 (610)	48 = 48 (1219)
30 = 30 (762)	60 = 60 (1524)
Tank size, gal (L):	
1500 = 1500 (5678)	

Prelos® Processor

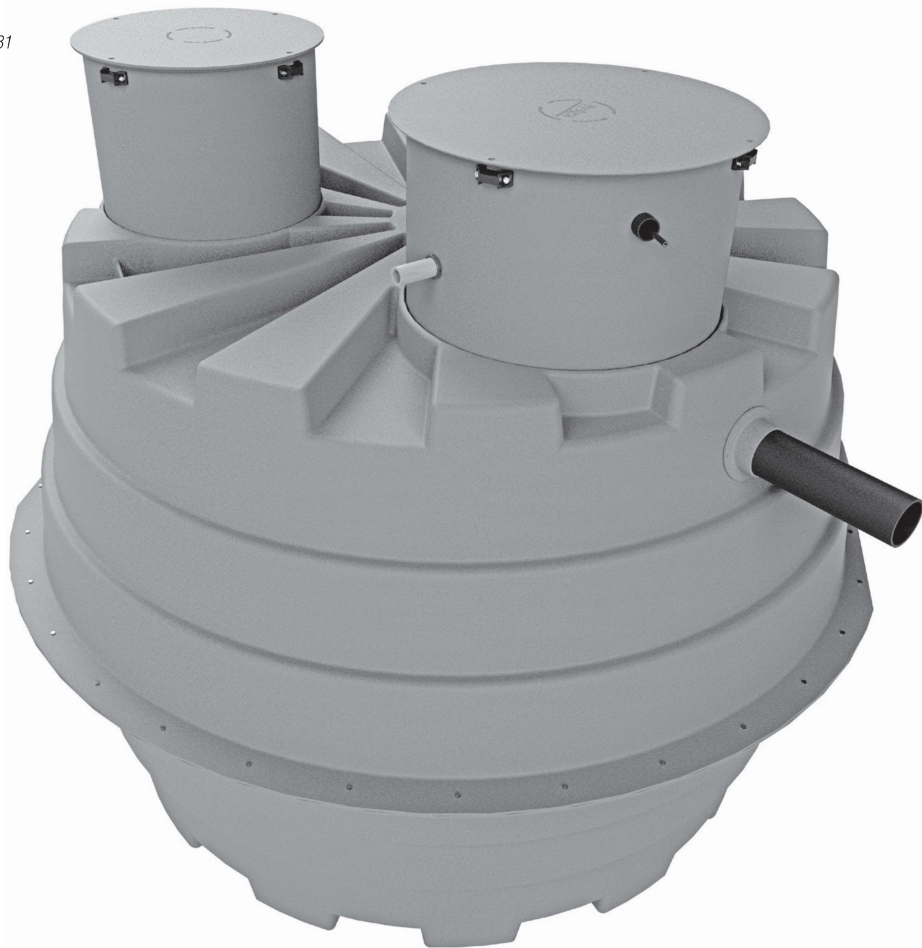

The Prelos 1500 Processor offers complete, integrated storage and pumping of wastewater in a simple, effective package.

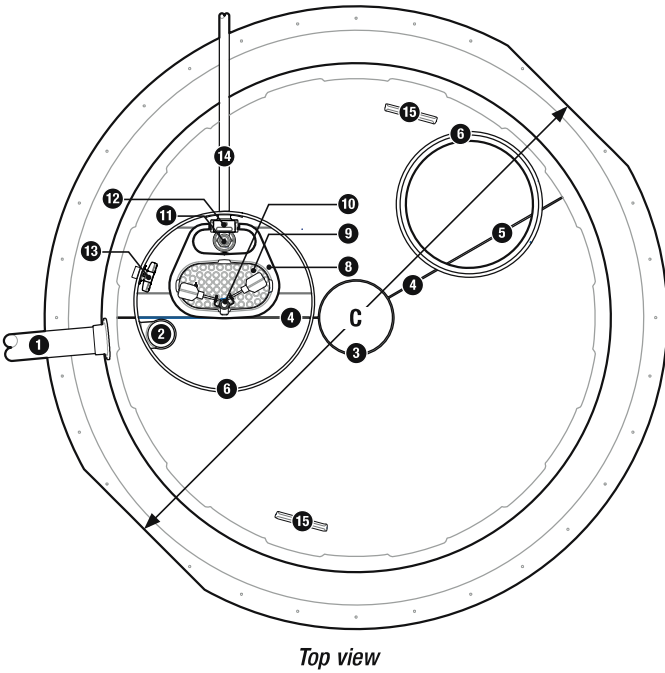
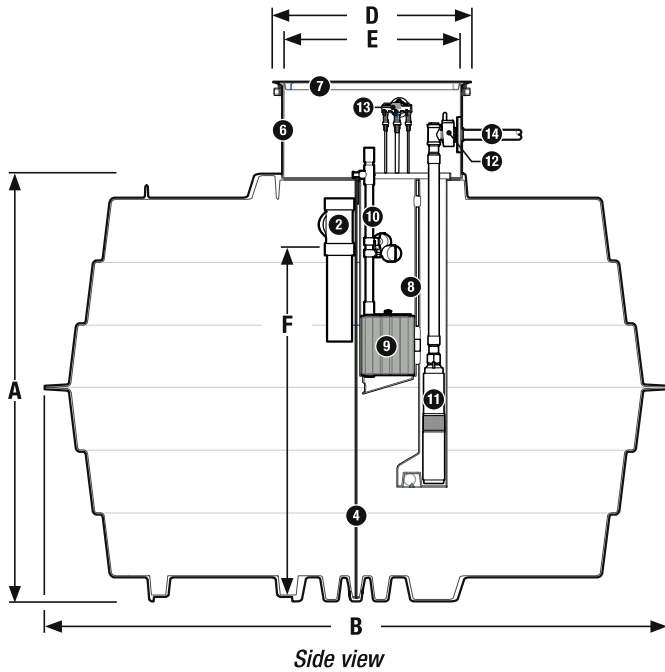

- | | | |
|-----------------------------|-------------------------|----------------------|
| ① Inlet | ⑥ Access riser | ⑪ Pump |
| ② Inlet tee | ⑦ Access lid | ⑫ Discharge assembly |
| ③ Support column | ⑧ Pump vault | ⑬ ClickTight™ |
| ④ Baffle wall (full-length) | ⑨ Biotube® filter | ⑭ Discharge |
| ⑤ Baffle pass-through | ⑩ Float switch assembly | ⑮ Lifting bracket |

Tank, Riser, and Lid

The Prelos 1500 Processor's meander-style tank has a patented design for superior performance. It's tough, impact-resistant, and light enough to install with small equipment. The standard 30-in. (750-mm) access riser, optional additional 24-in. (600-mm) riser, and access lids are designed to provide secure access to components inside of the Prelos 1500 Processor.

Materials of Construction

Access lid	Fiberglass, structural foam
Access lid hardware	Stainless steel
Access riser	Fiberglass
Inlet and inlet tee	ABS
Baffle wall	ABS
Support column	PVC, ABS
Tank body	DCPD

Dimensions

A. Tank height, in. (mm)	72 (1829)
B. Tank outside diameter, in. (mm)	105 (2667)
C. Tank width, flat-to-flat, in. (mm)	101 (2565)
D. Lid outside diameter, in. (mm)	33 (838)
E. Riser inside diameter, in. (mm)	29.5 (749)
F. Depth, nominal operating volume, in. (mm)	57 (1448)
Optional secondary riser lid outside dia., in. (mm)	24 (610)
Optional secondary riser inside dia., in. (mm)	23.5 (597)
Tank nominal operating volume, gal. (L)	1500 (5678)
Tank total volume, gal. (L)	1788 (6768)
Average volume at operating depth, gal./in. (L/mm)	25 (4)
Prelos Processor weight, nom., lbs (kg)	780-870 (354-395)

Pump Vault

The Prelos 1500 Processor's patent-pending pump vault is designed to be passively self cleaning for reduced maintenance and service needs, with no need to remove the vault from the processor for cleaning.

Materials of Construction

Vault body	Polyethylene
------------	--------------

Vault Dimensions in (mm)

A	18.50 (470)
B	15.94 (405)
C	65.50 (1664)
D	15.20 (386)

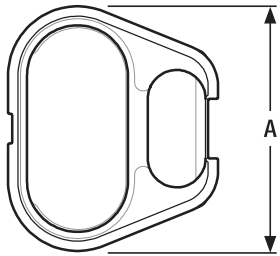

Prelos pump vault, top view

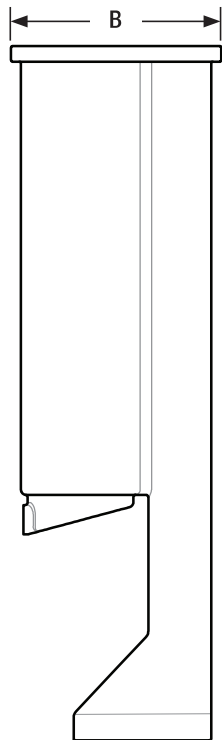

Prelos pump vault, side-cutaway view

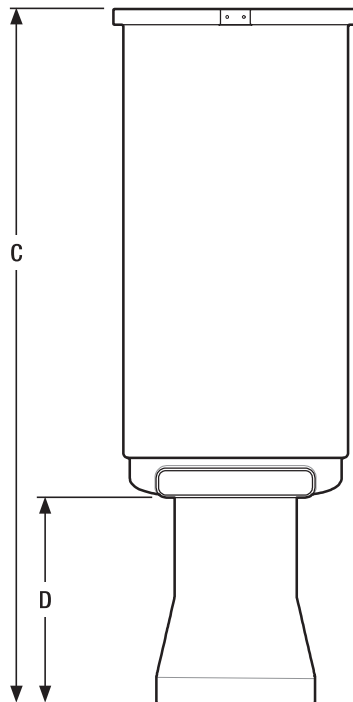

Prelos pump vault, front view

Biotube Effluent Filter

The Prelos 1500 Processor's Biotube effluent filter is designed for effective filtration of effluent and passive self cleaning for long maintenance cycle intervals.

Materials of Construction

End plates	DCPD
Filter tubes	Polypropylene
Handle assembly	Sch. 40 PVC
Screws	Stainless steel

Dimensions in (mm)

A	16.5 (419)
B	10.0 (254)

Performance

Biotube mesh opening, in (mm)*	0.125 (3)
Total filter flow area, ft ² (m ²)	4.0 (0.37)
Total filter surface area, ft ² (m ²)	14.0 (1.3)

*0.062in (1.6mm) filter mesh available

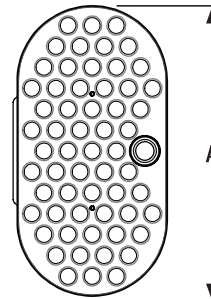

Biotube filter cartridge, top view

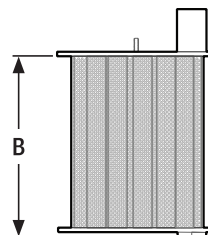

Biotube filter cartridge, side view

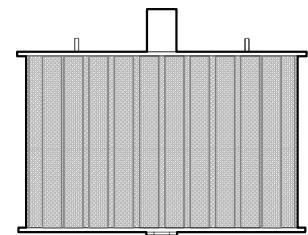

Biotube filter cartridge, front view

4in (100mm) Effluent Pump

Pumps used in Prelos 1500 Processors are Orenco's PF-Series pumps. They're field serviceable with common tools and, in internal testing, have a minimum 24hr run-dry capability (liquid end) with no deterioration in pump life or performance. These pumps are equipped with Type SOOW 600V power cords (suitable for Class I, Division 1 and 2 applications); they also meet UL requirements and are CSA certified to US and Canadian safety standards for effluent pumps.

Materials of Construction

Connector	Glass-filled thermoplastic, silicone
Diffusers	Glass-filled PPO
Discharge	Glass-filled polypropylene
Discharge bearing	Engineered thermoplastic (PEEK)
Impellers	Acetal
Intake screens	Polypropylene
Lubricant	Deionized water, propylene glycol
Suction connection, drive shaft, coupling, shell	Stainless steel

Specifications

Nominal flow, gpm (L/sec)	10 (0.6)
Length, in (mm)	23 (584)
Weight, lb (kg)	26 (12)
Discharge, in (nominal)	1.25
Impellers	6

Performance

hp (kW)	0.5 (0.37)
Design flow amps	12.7
Rated cycles/day	300
Minimum liquid level, in (mm)*	16 (406)

* Minimum liquid level is for a single pump installed in a pump vault.

Pump Curve

This graph shows the pump's performance range and the relationship between flow (gpm) and pressure (TDH).

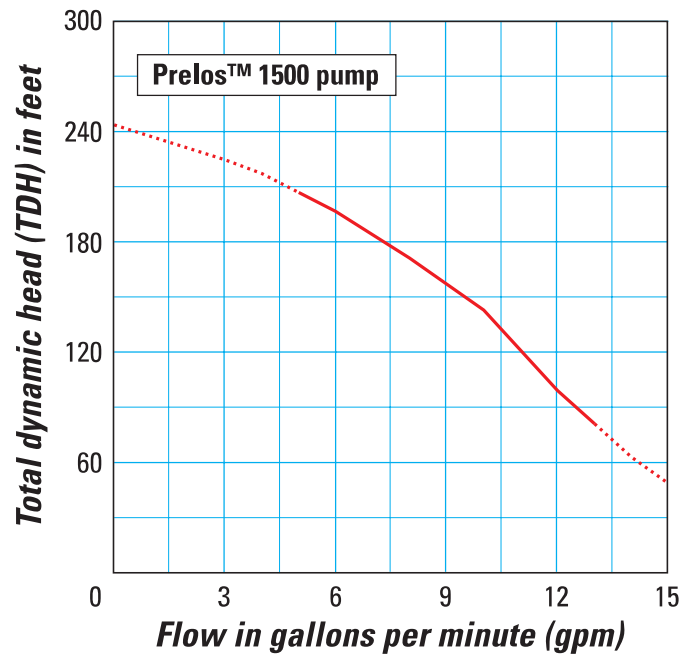

HDA-Series Discharge Assembly

Discharge assemblies used in Prelos 1500 Processors are designed for durability and ease of maintenance.

Materials of Construction

Anti-siphon valve	Sch. 80 PVC, EPDM, stainless steel
Discharge nipple	Sch. 80 PVC
Flexible hose	Reinforced EPDM
Flow control disc	Sch. 80 PVC
Hose fittings, tee fitting, mounting screws	Stainless steel
In-line check valve	Sch. 80 PVC, EPDM, stainless steel
Mounting plate	ABS
Quick-disconnect	Glass-filled thermoplastic

Working Pressures and Dimensions

Unit working pressure, psi (kPa)	150 (1034)
Height, mounting plate, in (mm)	7 (178)
Width, mounting plate, in (mm)	7 (178)
Diameter, discharge nipple, in*	1.25
Diameter, flow control disc orifice, in (mm)	0.25 (6.35)

* Contact your Orenco distributor about fittings to connect discharge assemblies to metric-sized piping.

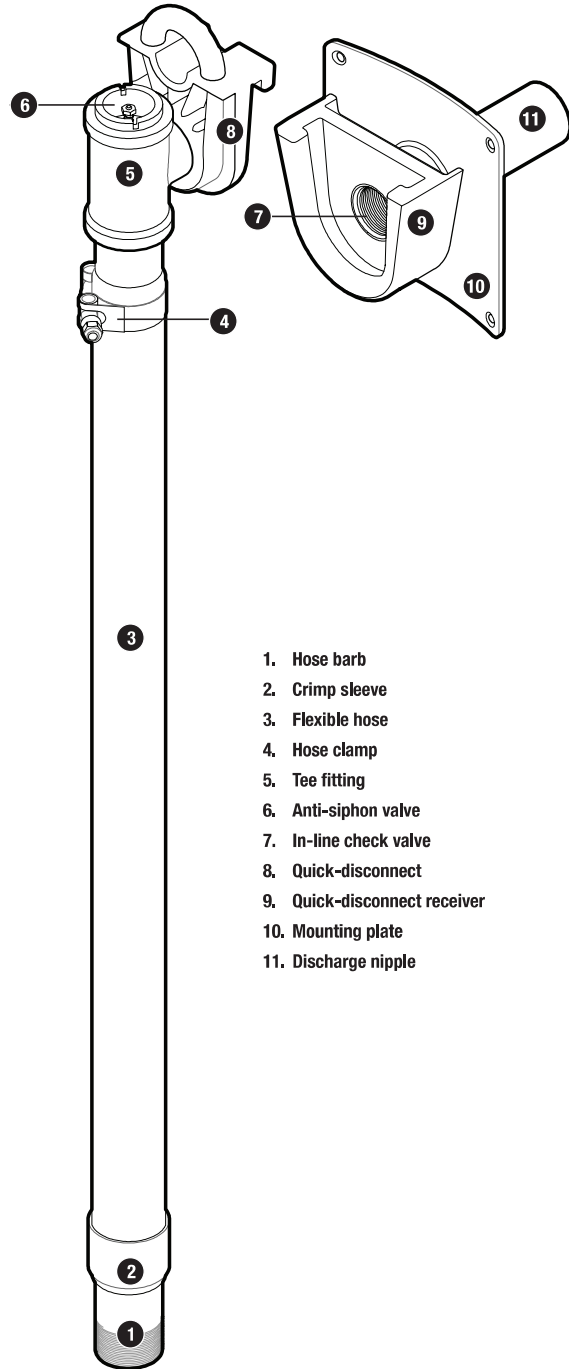

1. Hose barb
2. Crimp sleeve
3. Flexible hose
4. Hose clamp
5. Tee fitting
6. Anti-siphon valve
7. In-line check valve
8. Quick-disconnect
9. Quick-disconnect receiver
10. Mounting plate
11. Discharge nipple

HDA-Series discharge assembly

Float Switches

Float switches used in Prelos 1500 Processors are UL listed and CSA certified for use in water or sewage. To simplify accessing and servicing, the float switch assembly has been incorporated into the Biotube filter handle.

Materials of Construction

ClickTight connector	Glass-filled thermoplastic, silicone
Float collar	ABS
Float cord	Flexible, 2 conductor (UL, CSA), SJOW; CPE cord jacket with EPDM insulated conductors
Float housing	Impact-resistant, noncorrodible polypropylene for use in liquids up to 140°F (60°C)

Float Switch Specifications

Float	State	Type
P	Normally open	Mechanical

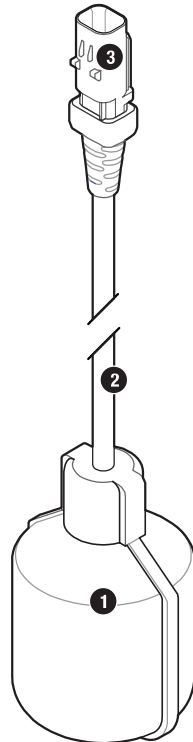
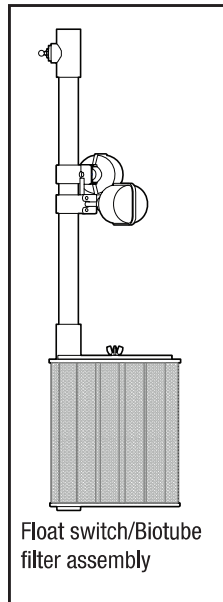

1. Float switch
2. Float switch cord
3. Float switch connector

ClickTight mechanical float switch

ClickTight

Orenco's ClickTight provides secure, moisture-resistant cable connections between the pump, float switches, and control panel in the Prelos 1500 Processor. ClickTight is UL listed for the US and Canada.

Materials of Construction

Cable	PVC/nylon, annealed copper; Type TC
Connectors	Glass-filled thermoplastic, silicone
Fastener	Stainless steel
Housing	ABS
O-ring	Buna-N
Potting compound	Urethane

Specifications

Cable rating	14AWG; 3 conductor; UL TC-ER 600V (pump) 18AWG; 2-8 conductor; UL TC-ER 600V (float)
Float switch connectors	double-pole
Pump connector	triple-pole
Maximum cable length, ft (m)	62 (19)

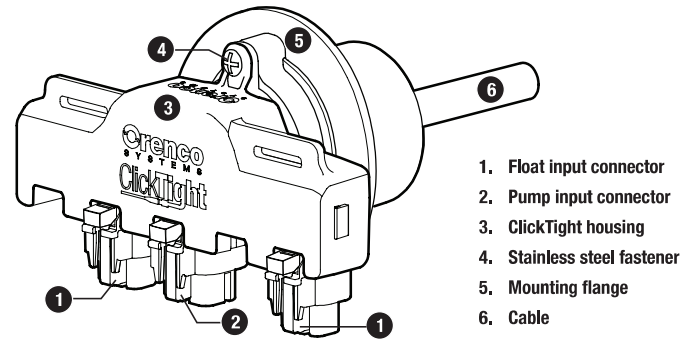

ClickTight

S1HR Control Panel

The Prelos 1500 Processor uses Orenco's S1HR control panel, which is ideal for Prelos Sewers and other effluent sewer applications.

Materials of Construction

Enclosure	UV-resistant fiberglass, UL Type 4X
Hinges	Stainless steel

Dimensions, in (mm)

Height	11.5 (292)
Width	9.3 (236)
Depth	5.4 (137)

Specifications

Panel ratings	120VAC, 1hp (0.75kW), 16A, single-phase, 60Hz
Motor-start contactor	16FLA, 1hp (0.75kW), 60Hz; 2.5 million cycles at FLA
Circuit breakers	120VAC, 10A, single-pole (control) 120VAC, 20A, single-pole (pump)
Toggle switch	Single-pole, double-throw HOA switch
Audio alarm	95dB at 24in (610mm), warble-tone sound; gasketed, UL Type 4X (IP 66)
Redundant high-on relay	120VAC, DIN rail mounted; provides a secondary pump-on signal during high-level conditions
Audio alarm silence relay	120VAC, automatic reset, DIN rail mount
Visual alarm	7/8in (22mm) diameter red lens, "push-to-silence," 120VAC LED, UL Type 4X

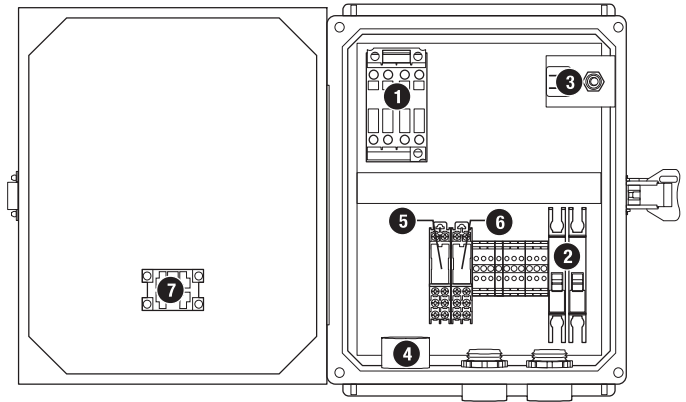

S1HR control panel

1. Motor-start contactor
2. Circuit breakers
3. Toggle switch
4. Audio alarm
5. Redundant high-on relay
6. Audio alarm silence relay
7. Visual alarm

PVP-Series Biotube® Pump Vaults

Applications

Orenco's patent-pending PVP-Series Biotube Pump Vaults are for use with Orenco 4in (100mm) submersible effluent pumps. PVP-Series pump vaults are ideal for all types of wastewater treatment systems, such as liquid-only sewers and on-site treatment systems. These vaults house one or two Orenco high-head effluent pumps and can be used in single-compartment septic tanks with flows up to 40gpm (2.5L/sec). For flows exceeding this rate, a double-compartment septic tank or separate dosing tank is recommended.



PVP-Series Pump Vault, cross-sectional side view

General

The Orenco PVP-Series Biotube Pump Vault includes a molded polyethylene housing and an internal Biotube filter cartridge constructed of polypropylene and PVC. The pump vault keeps sludge and scum away from the filter, pump, and float switches, while the filter removes particles 1/8in (3.2mm) or larger from the tank's clear zone. This reduces suspended solids by two-thirds, on average, and allows clear effluent to be discharged.* The passively self-cleaning design extends maintenance cycle intervals. The filter cartridge can be removed without pulling the pump or the vault. PVP-series vaults can accommodate one or two high-head effluent pumps.

* [Filter Facts](#), Orenco Product Fact Sheet.

Product Code Diagram

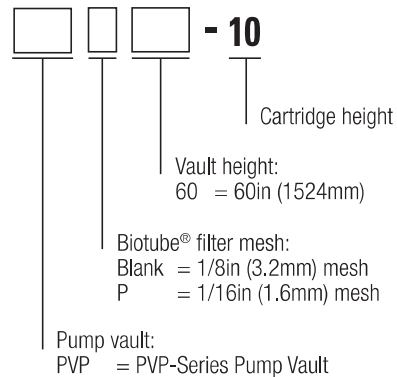

Tank Access and Riser Diameters

Diameter, in (mm)	PVP with simplex pump	PVP with duplex pumps
Tank access, minimum	18 (457)	18 (457)
Tank access, maximum	20 (508)	24 (600)†
Riser, minimum	24 (600)	30 (750)

† An extension kit, product code PVP-AEK, is required for tank access openings larger than 19in (483mm) in 30in (750mm) risers.

All product and performance assertions are based on proper design, installation, operation, and maintenance according to Orenco's current published documentation.

Pump Vault

Orenco's patent-pending PVP-Series Biotube Pump Vault is designed to be passively self-cleaning for reduced maintenance and service needs.

Materials of Construction

Vault body	Polyethylene
------------	--------------

Dimensions, in (mm)

A.	22 (559)
B.	16.63 (422)
C.	60 (1524)
D. Inlet height	10.88 (276)
E. Lowest float switch setting point	31 (787)
F.	2 (51)

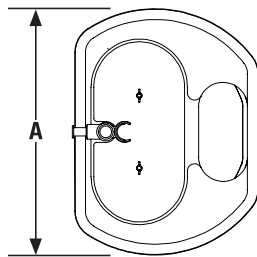

PVP-series pump vault, top view

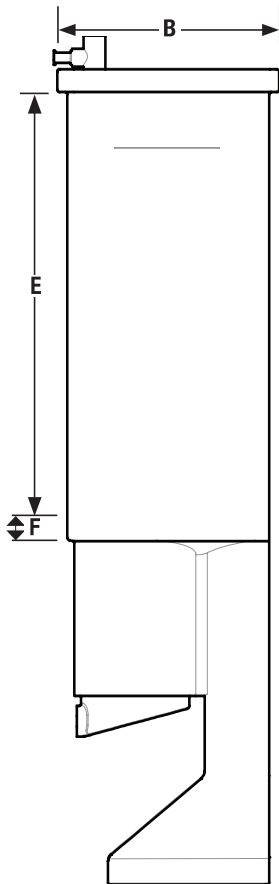

PVP-series pump vault, side view

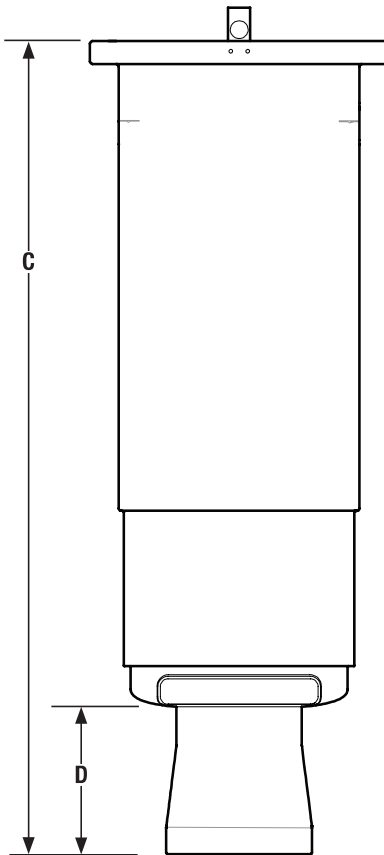

PVP-series pump vault, front view

Biotube Filter

The Orenco PVP-Series Biotube filter is designed for effective filtration of effluent and passive self-cleaning for long cleaning intervals.

Materials of Construction

End plates	DCPD
Filter tubes	Polypropylene
Handle assembly	Sch. 40 PVC
Screws	Stainless steel

Dimensions, in (mm)

A.	16.50 (419)
B.	10 (254)

Performance

Biotube mesh, in (mm)*	0.125 (3)
Total filter flow area, ft ² (m ²)	4 (0.37)
Total filter surface area, ft ² (m ²)	14 (1.3)

*0.062in (1.6mm) filter mesh available

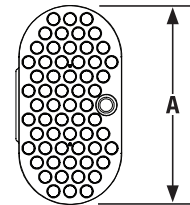

Biotube filter cartridge, top view

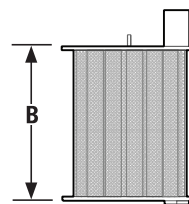

Biotube filter cartridge, side view

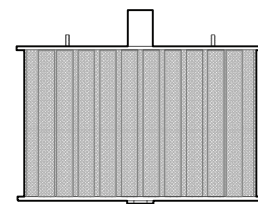

Biotube filter cartridge, front view

Pump Vault Adapter Extension Kit

The Orenco PVP-Series Biotube Pump Vault Adapter Extension Kit is required when using a 30in (750mm) riser with an access opening larger than 19in (483mm). The kit contains 2 brackets, 6 nuts, and 6 bolts.

Materials of Construction

Support brackets	Fiberglass reinforced polymer
Nuts and bolts	Stainless steel

Dimensions, in (mm)

A.	14 (356)
B.	6.5 (165)
C.	5.5 (127)
D.	27.9 (709)

Product Code Diagram

PVP - AEK

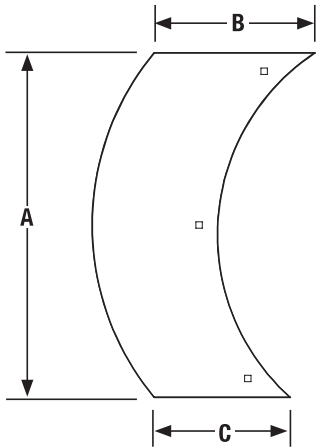

Single bracket from adapter kit

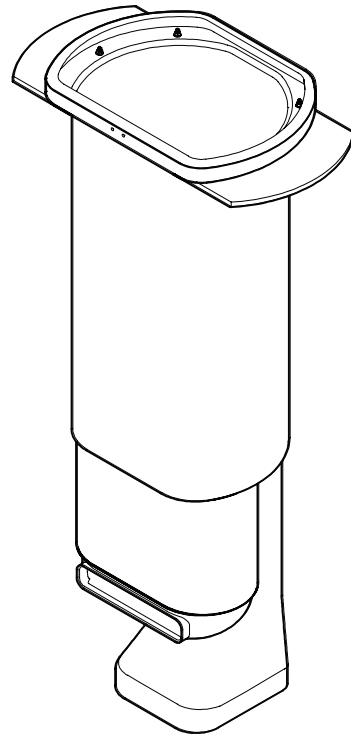

Adapter kit installed, isometric view

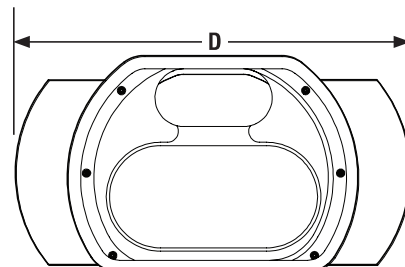

Adapter kit installed, top view

ClickTight™ Products

Applications

Orenco® ClickTight™ products provide secure, moisture-resistant cable connections between a ClickTight, a ClickTight-compatible pump, up to four ClickTight-compatible float switches, and a control panel. They eliminate the need for splice boxes, field-spliced wires, wire nuts, and conduit seals.

ClickTight is UL-listed for the US and Canada. ClickTight connectors are IP67 rated.

General

Orenco's ClickTight products greatly reduce the risk of electrical failures in wastewater systems due to moisture, faulty splices, improperly installed waterproof wire nuts, or corrosion. Two to four float switches and a pump are quickly and securely connected to the ClickTight, without the use of tools. An integral cable runs from the ClickTight to the control panel.

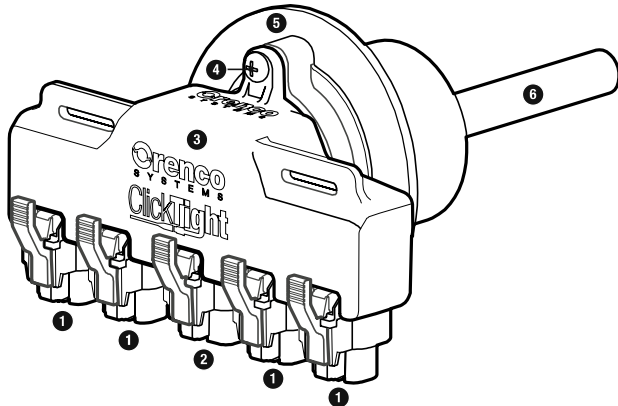

- 1 Float switch plugs, female
- 2 Pump plug, female
- 3 ClickTight™ connector
- 4 Stainless steel fastener
- 5 ClickTight coupler
- 6 ClickTight cable

ClickTight™

ClickTight™

Orenco's ClickTight greatly reduces the risk of electrical failures in onsite wastewater systems. It provides secure, water-resistant cable connections between a control panel, up to four ClickTight-compatible float switches, and a pump. It eliminates the need for splice boxes, field-spliced wires, wire nuts, and conduit seals.

ClickTight installs easily in an access riser, where it fits close to the riser wall to provide clearance for O&M activities. The ClickTight is fully potted and sealed to prevent moisture and corrosive gas from reaching the control panel.

Plug caps (product code CLK-CAP) are available for unused float switch plugs.

Materials of Construction

Cable	PVC/nylon, annealed copper
Connector housing	ABS
Coupler housing	ABS
Fastener	Stainless steel
O-ring	Buna N
Connectors	Glass-filled thermoplastic, silicone
Potting compound	Urethane

Specifications

Cable	14 AWG; 3-conductor; UL TC-ER 600V (pump) 18 AWG; 2-8 conductor; UL TC-ER 600V (float)
Cable length, maximum, ft (m)	62 (19)
Float switch connectors	2-pole, IP67
Pump connector	3-pole, IP67

Standard Models

CLK2-60, CLK3-60, CLK4-60

Product Code Diagram

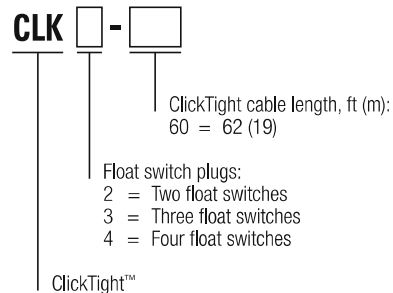

ClickTight Float Switches

ClickTight “B,” “C,” “N,” and “P” float switches are mechanical, non-mercury switches that are cUL-listed and CSA-certified for use in water or sewage. ClickTight “G” float switches are mercury switches.

Materials of Construction

Float switch collar	ABS
Float switch cord	Flexible, 2-conductor (UL, CSA) SJOW; water-resistant CPE cord jacket with EPDM insulated conductors
Float switch housing	Impact-resistant, noncorrosive polypropylene for use in liquids up to 140° F (60° C)
Float switch plug, male	Glass-filled thermoplastic, silicone, IP67

Float Switch Specifications

Float	State	Type
B	Normally open	Mechanical
C	Normally open	Mechanical
N	Normally closed	Mechanical
P	Normally open	Mechanical
G	Normally open	Mercury

Standard Models

B, C, N, P, G

Product Code Diagram

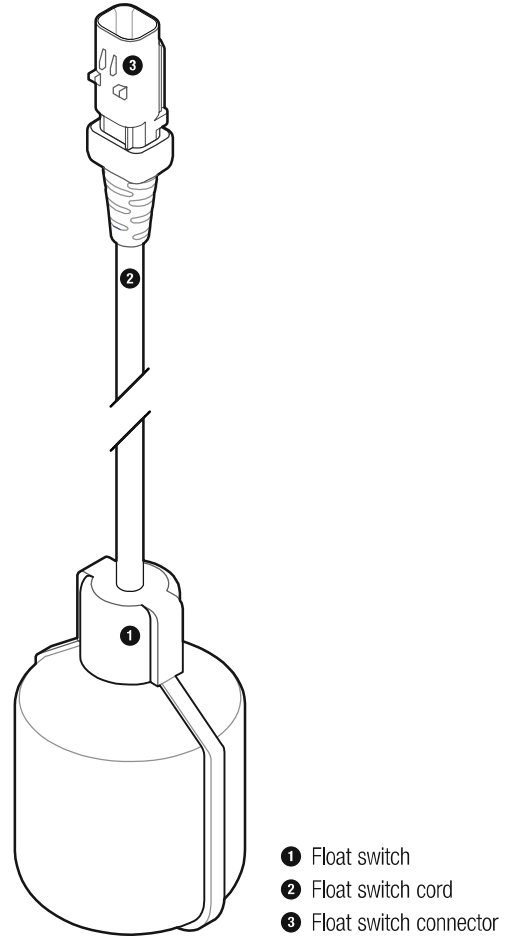
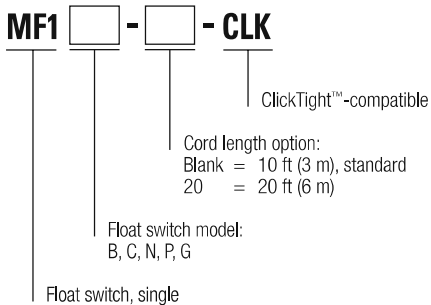

ClickTight float switch (mechanical float switch shown)

ClickTight™ Pump Cord Adapters

Orenco's ClickTight™ pump cord adapters provide a means of retrofitting a ClickTight pump connector to an existing Orenco pump or a customer-sourced, single-phase, 120V/240V pump of up to 1 hp (0.75 kW) and rating of 13 FLA.

Materials of Construction

Connector	Glass-filled thermoplastic, silicone
Heat shrink	Adhesive-filled polyolefin
Splice connector	Nylon, copper

Specifications

Pump adapter cord	3-conductor, 16 AWG, SOOW, 600V
Pump adapter cord plug, male	3-pole, IP67
Heat shrink	12-6 AWG, 600V
Splice connector	16-14 AWG

Product Code Diagram

CLK - PA

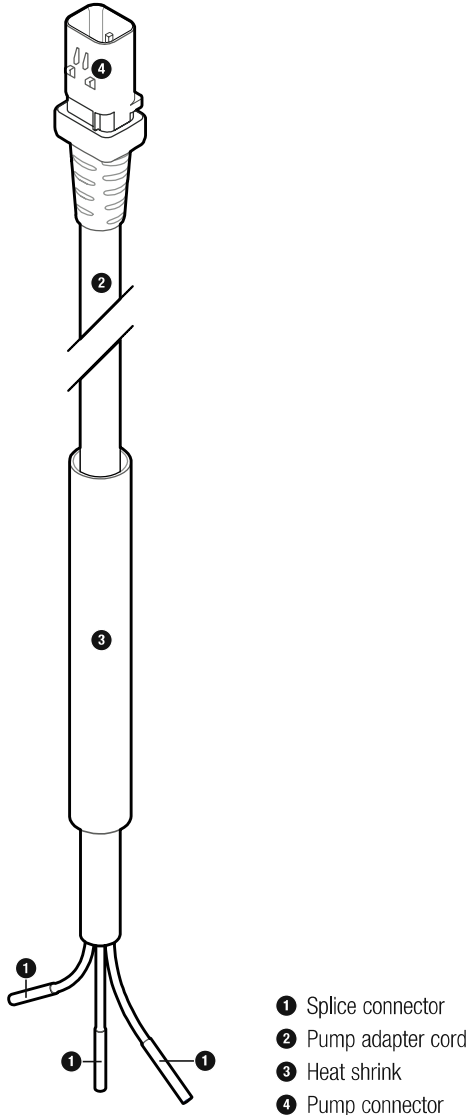
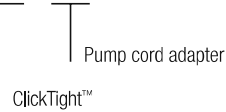

ClickTight pump cord adapter

ClickTight-Compatible Effluent Pumps

Orenco's ClickTight-compatible PF-Series 4-in. (100-mm) effluent pumps* are the fast and simple way to add pumping capability to the ClickTight Controls Package. They're field-serviceable with common tools and have a minimum 24-hour run-dry capability (liquid end) with no deterioration in pump life or performance, in internal testing.

* For PF-Series effluent pumps, see Orenco Tech Data Sheet NTD-PU-PF-1.
PVA-series pumps are also available. See Orenco Tech Data Sheet NTD-PU-PVA-1 for details.

Materials of Construction

Connector	Glass-filled thermoplastic, silicone, IP67
Diffusers	Glass-filled PPO
Discharge	Glass-filled polypropylene
Discharge bearing	Engineered thermoplastic (PEEK)
Impellers	Acetal
Intake screens	Polypropylene
Lubricant	Deionized water, propylene glycol
Suction connection, drive shaft, coupling, shell	Stainless steel

Standard Models

PF100511-CLK, PF100511CV-CLK, PF100512-CLK, PF100712-CLK,
PF200511-CLK, PF200512-CLK, PF300511-CLK, PF300512-CLK,
PF300712-CLK, PF500511-CLK, PF500512-CLK, PF500712-CLK,
PVA100511-CLK, PVA300511-CLK, PVA500511-CLK

Product Code Diagram

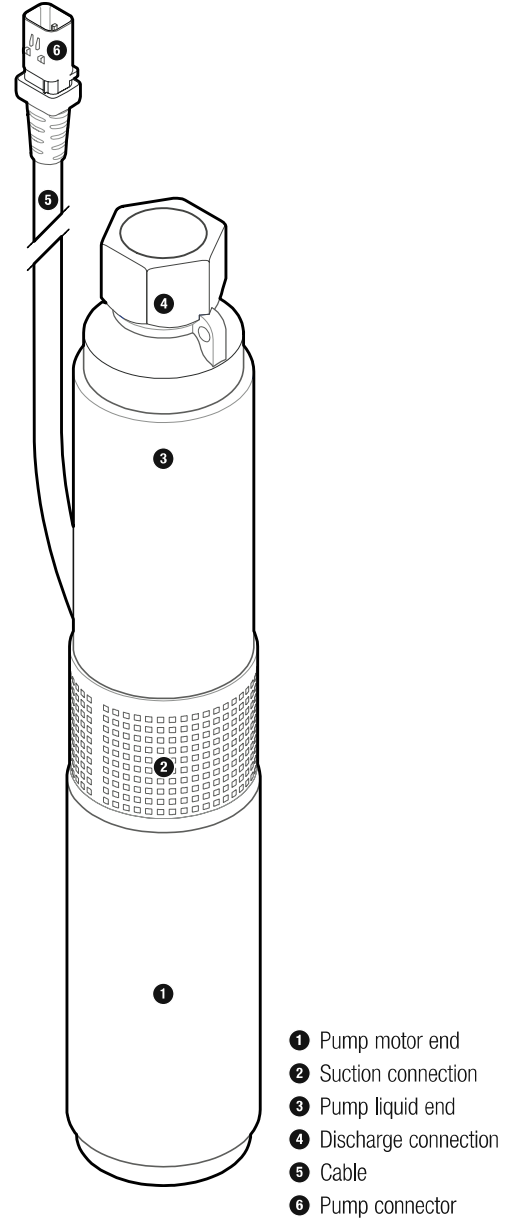
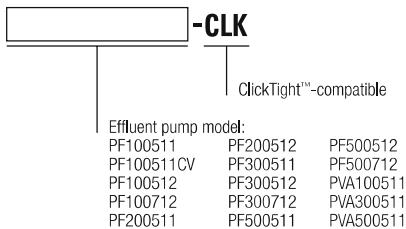

ClickTight-compatible effluent pump

HDA Discharge Assemblies

Applications

Orenco's HDA Discharge Assemblies are designed to work with 4-inch (100-mm) submersible effluent pumps to convey effluent to the exterior of a riser, tank or basin. They are not intended for "low-head" centrifugal pumps. HDA discharge assemblies are suitable for most pumping applications requiring simplex or duplex pumps. And they are ideal for sites with deep burial needs or cold weather conditions.

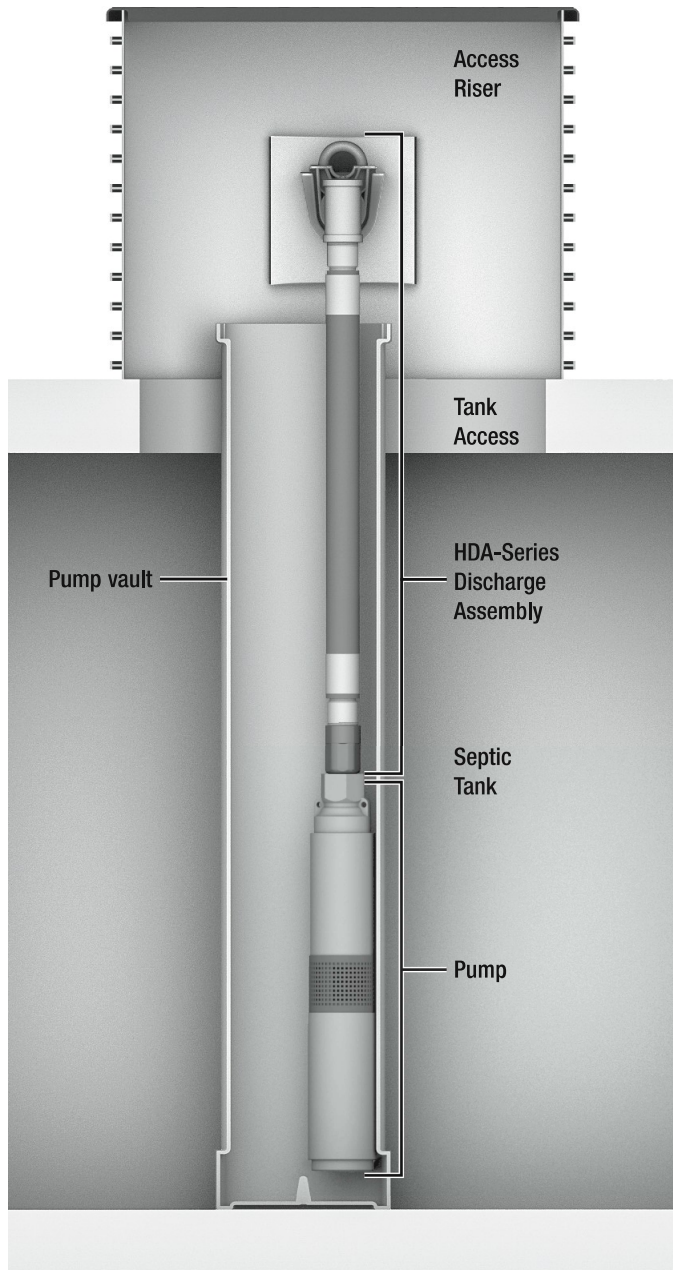

HDA Discharge Assemblies provide clear access to tank and basin components. (Cross-sectional illustration of simplex HDA installed in a typical concrete tank.)

General

HDAs are hanging-style discharge assemblies designed to provide a simple, durable, watertight installation and clear access to tank and basin components. They combine an ABS mounting plate with a quick-disconnect fitting and a section of flexible, high-pressure hose with stainless steel fittings. Hose length is determined by the system configuration. Contact your Distributor or Orenco for more information.

HDAs are rated for 10-, 20-, and 30-gpm pumps (0.6-, 1.3-, and 1.9-L/sec). They are extremely easy to remove and reinstall for servicing with a simple tool (HDATool), available separately for purchase.

Standard Models

HDAS24125CFCASLC-XX

HDAD24125CFCASLC-XX

HDATool

Product Code Diagram

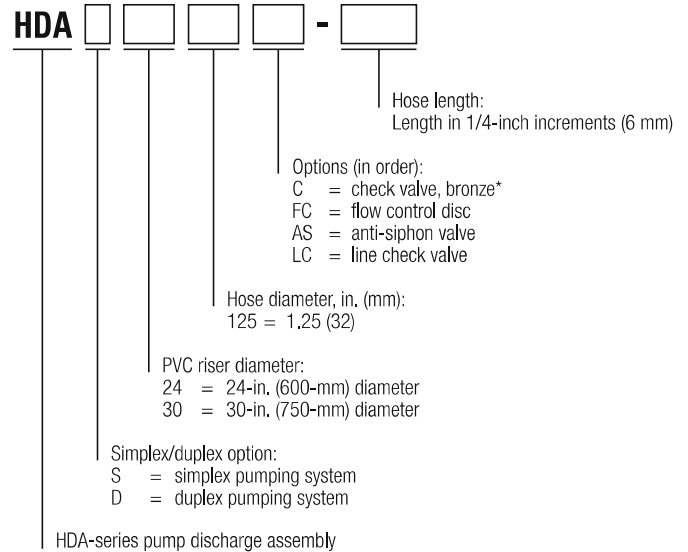

* Bronze check valves are not needed if the pump used has an internal check valve. Orenco's PF100511CV pump is equipped with an internal check valve.

Materials of Construction

HDA

Anti-siphon valve	Sch. 80 PVC, EPDM, stainless steel
Check valve	Bronze
Crimp sleeve	Stainless steel
Discharge nipple	Sch. 80 PVC
Flexible hose	Reinforced EPDM
Flow control disc	Sch. 80 PVC, 1/8-inch (3.2 mm) orifice
Hose barb	Stainless steel
Line check valve	Sch. 80 PVC, EPDM, stainless steel
Mounting plate	ABS (simplex), fiberglass (duplex)
Mounting plate screws	Stainless steel
Quick-disconnect	Glass-filled thermoplastic
Tee fitting	Stainless steel

HDATOOL

Handle	Fiberglass
Tool head	Stainless steel
End cap	Rubber

Working Pressures and Dimensions

Model	HDAS24125C-XX	HDAD24125C-XX
Unit working pressure, psi (kPa)	150 (1034)	150 (1034)
Height, mounting plate, in. (mm)	7 (178)	7 (178)
Width, mounting plate, in. (mm)	7 (178)	14 (356)
Diameter, discharge nipple, in. (mm)	1¼ (32)	1¼ (32)
Diameter, flow control disc orifice, in. (mm)	¼ (6.35)	¼ (6.35)

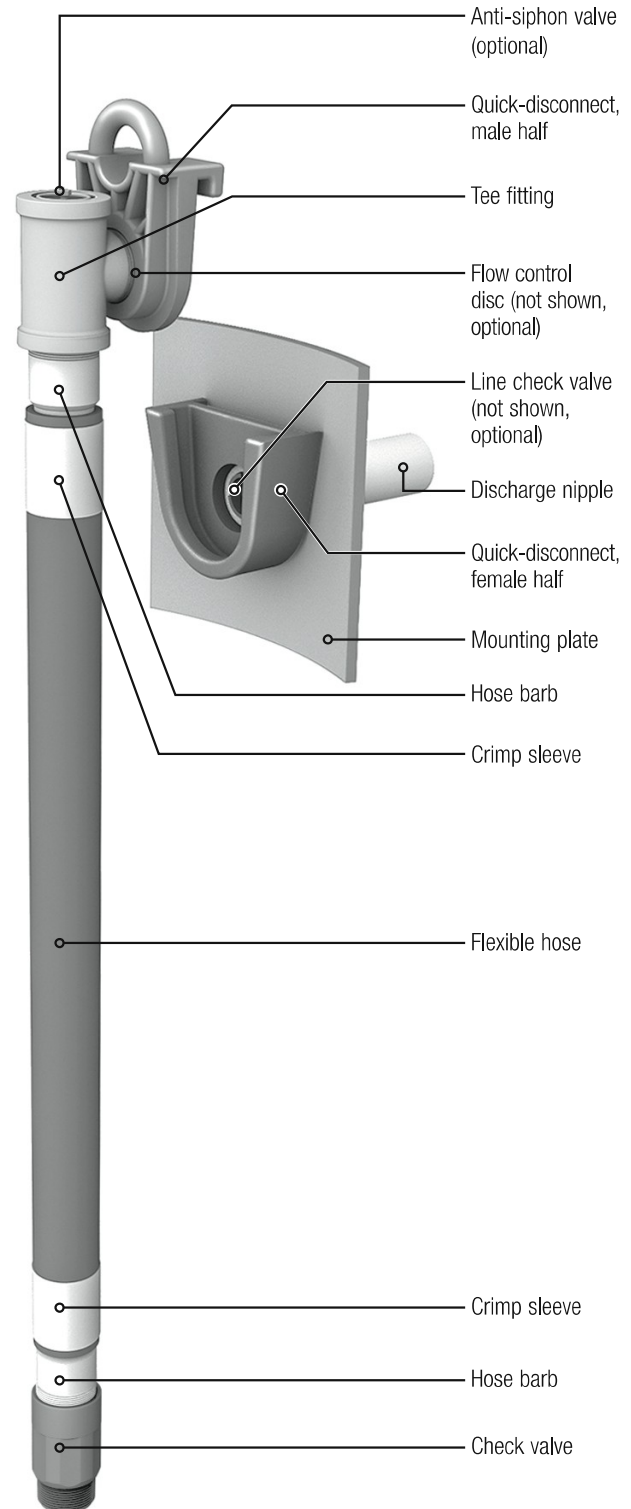

HDA Discharge Assemblies are constructed of durable, corrosion-resistant parts that are designed to work together for a long service life. (Simplex model shown.)

Hose Length Selection Chart

Correct HDA Hose Length for Pump and PVU Model, in. (mm)*							
Pump	PVU48	PVU57	PVU68	PVU72	PVU84	PVU95	PV55
PF100511CV ²	24.00 (610)	33.00 (838)	44.00 (1118)	48.00 (1219)	60.00 (1524)	71.00 (1803)	31.75 (806)
PF10051X	21.00 (533)	30.00 (762)	41.00 (1041)	45.00 (1143)	57.00 (1448)	68.00 (1727)	27.75 (705)
PF100712	18.00 (457)	27.00 (686)	38.00 (965)	42.00 (1067)	54.00 (1372)	65.00 (1651)	24.75 (629)
PF15031X	24.50 (622)	33.50 (851)	44.50 (1130)	48.50 (1232)	60.50 (1537)	71.50 (1816)	31.25 (794)
PF20051X	21.75 (552)	30.75 (781)	41.75 (1060)	45.75 (1162)	57.75 (1467)	68.75 (1746)	28.50 (724)
PF201012	15.50 (394)	24.50 (622)	35.50 (902)	39.50 (1003)	51.50 (1308)	62.50 (1588)	22.25 (565)
PF201512	10.00 (254)	19.00 (483)	30.00 (762)	34.00 (864)	46.00 (1168)	57.00 (1448)	16.75 (425)
PF30051X	22.75 (578)	31.75 (806)	42.75 (1086)	46.75 (1187)	58.75 (1492)	69.75 (1772)	29.50 (749)
PF300712	19.25 (489)	28.25 (718)	39.25 (997)	43.25 (1099)	55.25 (1403)	66.25 (1683)	26.00 (660)
PF301012	17.00 (432)	26.00 (660)	37.00 (940)	41.00 (1041)	53.00 (1346)	64.00 (1626)	23.75 (603)
PF301512	11.25 (286)	20.25 (514)	31.25 (794)	35.25 (895)	47.25 (1200)	58.25 (1480)	18.00 (457)
PVA100511	22.00 (559)	31.00 (787)	42.00 (1067)	46.00 (1168)	58.00 (1473)	69.00 (1753)	28.75 (730)
PVA300511	23.50 (597)	32.50 (826)	43.50 (1105)	47.50 (1207)	59.50 (1511)	70.50 (1791)	30.25 (768)
PF10053200	21.00 (533)	30.00 (762)	41.00 (1041)	45.00 (1143)	57.00 (1448)	68.00 (1727)	30.75 (781)
PF10073200	18.50 (470)	27.50 (699)	38.50 (978)	42.50 (1080)	54.50 (1384)	65.50 (1664)	25.25 (641)
PF20053200	21.75 (552)	30.75 (781)	41.75 (1060)	45.75 (1162)	57.75 (1467)	68.75 (1746)	28.50 (724)
PF20103200	16.25 (413)	25.25 (641)	36.25 (921)	40.25 (1022)	52.25 (1327)	63.25 (1607)	23.00 (584)
PF20153200	13.25 (337)	22.25 (565)	33.25 (845)	37.25 (946)	49.25 (1251)	60.25 (1530)	20.00 (508)
PF30053200	22.75 (578)	31.75 (806)	42.75 (1086)	46.75 (1187)	58.75 (1492)	69.75 (1772)	29.50 (749)
PF30073200	19.50 (495)	28.50 (724)	39.50 (1003)	43.50 (1105)	55.50 (1410)	66.50 (1689)	26.25 (667)
PF30103200	17.50 (445)	26.50 (673)	37.50 (953)	41.50 (1054)	53.50 (1359)	64.50 (1638)	24.25 (616)
PF30153200	14.25 (362)	23.25 (591)	34.25 (870)	38.25 (972)	50.25 (1276)	61.25 (1556)	21.00 (533)
PF301534	14.50 (368)	23.50 (597)	34.50 (876)	38.50 (978)	50.50 (1283)	61.50 (1562)	21.25 (540)

* Hose lengths shown are based on a discharge hole center height of 8 inches (200 mm) from the bottom of the riser and with the pump vault's support pipes resting on the top of the tank. These lengths also work for a discharge hole center height 11 inches (279 mm) from the bottom of the riser when using an Orenco RRFTA24 or FRFTA24-RVF tank adapter on a tank. Other factors may affect the hose length selection process. Contact Orenco for more details.

Orenco DuraFiber™ FLD Access Lids

Applications

Orenco DuraFiber FLD Access Lids provide secure, durable, watertight coverings for ribbed PVC, HDPE, and Orenco FRP risers, pump basins, and access ports. They are capable of supporting a 2500lb (1134kg) load; however, they are not recommended for vehicular traffic.

FLD24 24in (600mm) lids require an RLA24 adapter to connect to Perma-Loc™ pipe. FLD30 30in (750mm) lids are not compatible with RLA30 Riser-Lid-Adapters or 30in (750mm) Perma-Loc pipe.

General

DuraFiber FLD lids are designed for extreme durability and damage resistance, with UV- and corrosion-resistant materials, optional EPDM gaskets for watertight lid-to-riser connections, and flat-style flanges for easy access with clean, flush-to-grade installations. They also have centering rings for easy alignment. FLD lids feature a non-skid surface and a molded-in caution statement, with room for a customer logo. All come with four 5/16in stainless steel socket cap screws and a hex key wrench.

FLD lids are available with optional insulation, installed at the factory or in kits that can be installed in the field.

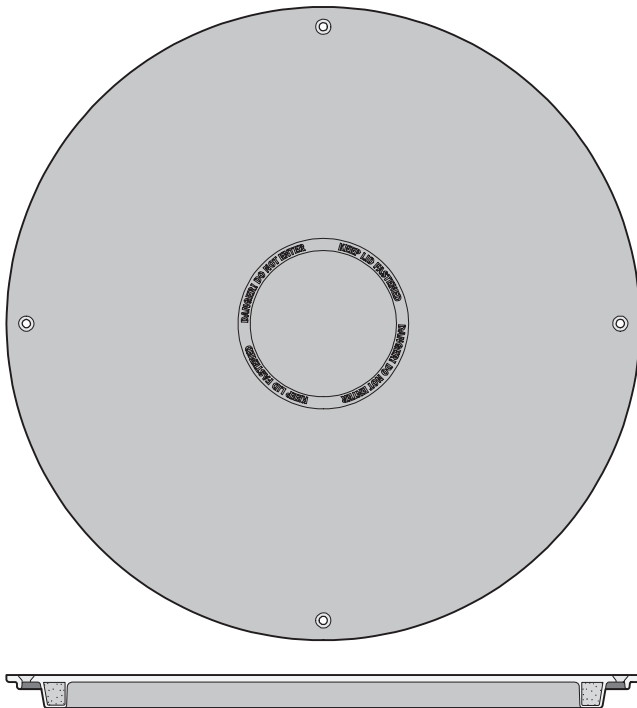

DuraFiber FLD lid: top view and side-cutaway view

Standard Models

FLD18G, FLD24G, FLD24G-ATX, FLD24G-W, FLD30G, FLD30G-ATX, FLD30G-PRELOS, FLD30G-W

Product Code Diagram

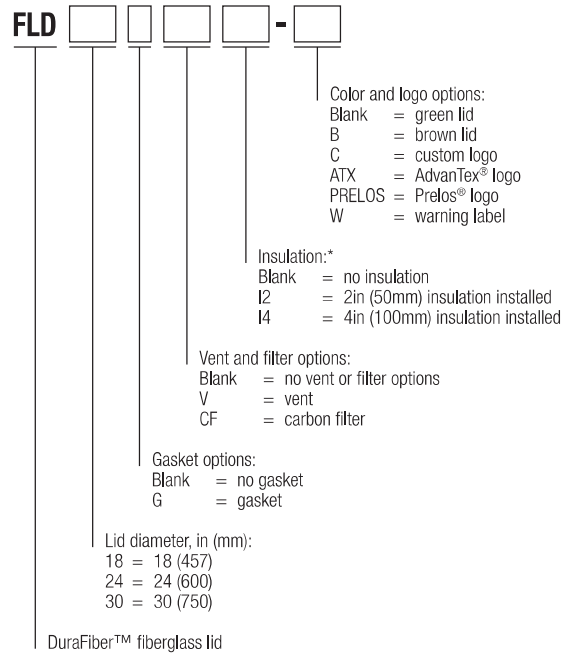

*Insulation has an R-value of 10 per 2in (RSI of 1.8 per 50mm) increment

Materials of Construction

Lid	Fiber-reinforced polymer (FRP)
Gasket (FLD18)	Urethane
Gasket (FLD24, FLD30)	EPDM
Centering ring core	Structural foam
Mounting hardware	Stainless steel
Insulation, optional	Closed-cell foam
Insulation mounting hardware	Stainless steel

Specifications

Model	FLD18XX	FLD24XX	FLD30XX
A in (mm)	20.2 (514)	25.75 (654)	32.75 (832)
B in (mm)	1.5 (38)	1.5 (38)	1.5 (38)
C in (mm)	17.5 (445)	23.25 (591)	29.25 (743)
Insulation R-value per 2in (RSI per 50mm) increment	10 (1.8)	10 (1.8)	10 (1.8)
Gasket width, in (mm)	0.75 (19)	0.69 (18)	0.69 (18)
Bolt hole diameter, in (mm)	0.3125 (8)	0.3125 (8)	0.3125 (8)
Weight, lbs (kg)	7 (3)	11 (5)	20 (9)
Bolt holes per lid	4	4	4

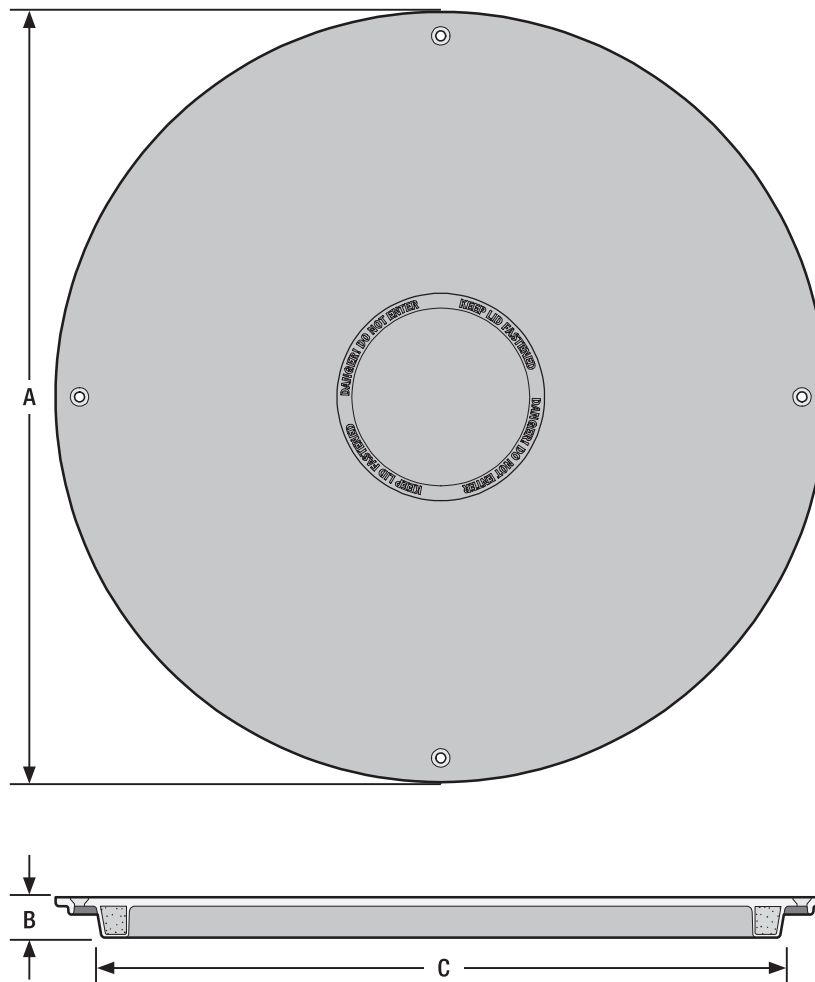

FRP Access Risers

Applications

Orenco FRP (fiberglass-reinforced polymer) Access Risers are designed to provide access to septic tank openings, as well as watertight connections between the tank, riser, and lid. They can be cast into the tops of concrete tanks or bonded to a fiberglass or dicyclopentadiene (DCPD) tank. Orenco FRP Access Risers can also be used as valve enclosures.

The RF24 and RF30 FRP access risers are designed for use with Orenco's FLD access lid.

General

Orenco FRP Access Risers are constructed of filament-wound fiberglass to be lightweight, corrosion resistant, and extremely strong. Risers are available in 24in and 30in (600mm and 750mm) diameters, with heights available in 3in (75mm) increments. They have four bolt catches to secure access riser lids and are compatible with Orenco tank adapters. See <https://www.orenco.com/products/gravity-pump-products/access-risers/riser-tank-adapters> for information on adapters.



Orenco FRP Access Risers are available in 24in and 30in (600mm and 750mm) diameters.

Riser Wall Thickness

Length	RF24XX	RF30XX
Up to 8ft (2.4m)	0.1875in (5mm)	0.25in (6mm)
8ft (2.4m) - 12ft (3.7m)	0.3125in (8mm)	0.3125in (8mm)
Over 12ft	Custom	Custom

Standard Models

RF24XX, RF30XX

Product Code Diagram

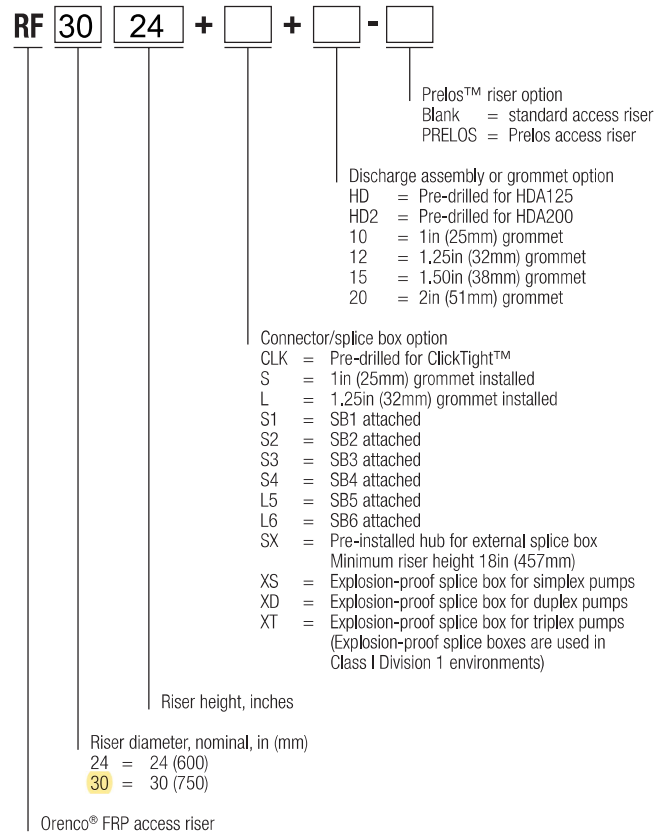

Materials of Construction

Access riser	Fiberglass-reinforced polymer
Bolt catches	Glass-filled nylon
Hardware	Stainless steel

Specifications

Model	RFP24	RFP30
Inside diameter, in (mm)	23.5 (597)	29.5 (749)
Outside diameter, in (mm)	24 (600)	30 (750)
Weight, lb/ft (kg/m)	11 (16)	18 (27)

S-Series Simplex Control Panels

Applications

Orengo® S-Series Simplex Control Panels control single pumps in effluent sewer (STEP) systems, onsite septic systems, and for pump control into conventional gravity sewer systems.

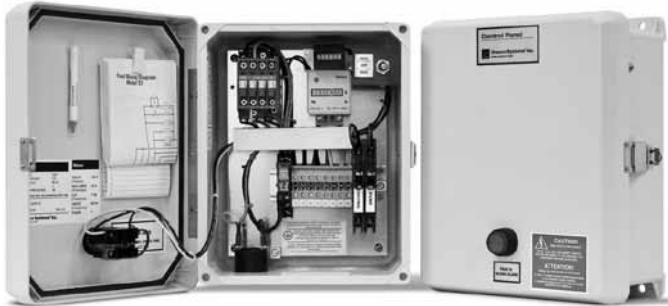

Orengo S-Series Simplex Control Panel (S1ETMCT shown)

Materials of Construction

Component	Material
Enclosure	UV-resistant fiberglass, Type 4X (IP 66)
Hinge	Stainless steel
Latch	Stainless steel

Specifications

Feature	Specifications
Height, in. (mm)	11.5 (292)
Width, in. (mm)	9.3 (236)
Depth, in. (mm)	5.4 (137)
S1 panel ratings*	120 VAC, 1 hp (0.75 kW), 16 A, 1-phase, 60 Hz
S2 panel ratings*	240 VAC, 3 hp (2.24 kW) 16 A, 1-phase, 60 Hz

* Pump motors used with these panels require internal overload protection.

General

Orengo® S-Series Simplex Control Panels are electro-mechanical panels for controlling single pumps. Standard features include an Automatic/Off/Manual (Auto/Off/Man) toggle switch, controls circuit breaker, pump circuit breaker, automatic motor control operation, and an audible/visible high water level alarm with auto reset. Specifications for standard and optional features are listed on page 2.

All S-Series control panels have a 120 VAC controls circuit breaker. S1 panels have a 120 VAC pump circuit breaker, while S2 panels have a 240 VAC pump circuit breaker.

All S-Series panels can be used with both mechanical and mercury float switches.

Listed per UL-508 and cUL-508; CE-listed versions of S-Series panels are available.

Standard Models

S1, S2

Nomenclature

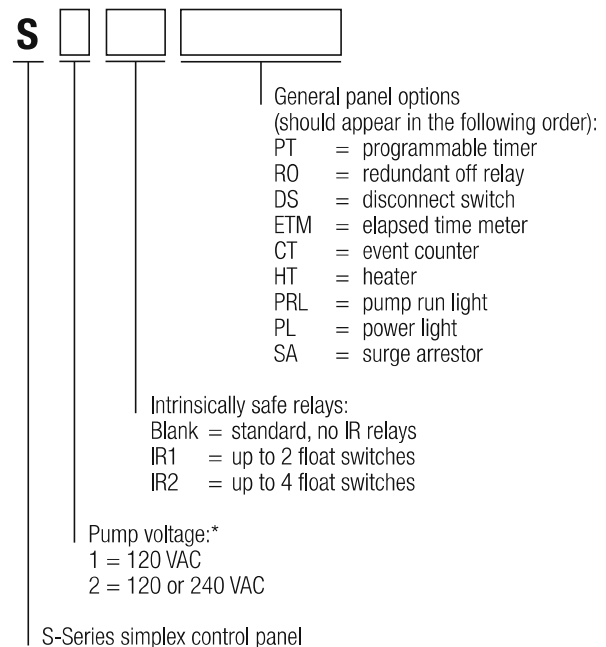

* All controls circuits require 120 VAC power

S-Series Simplex Control Panels

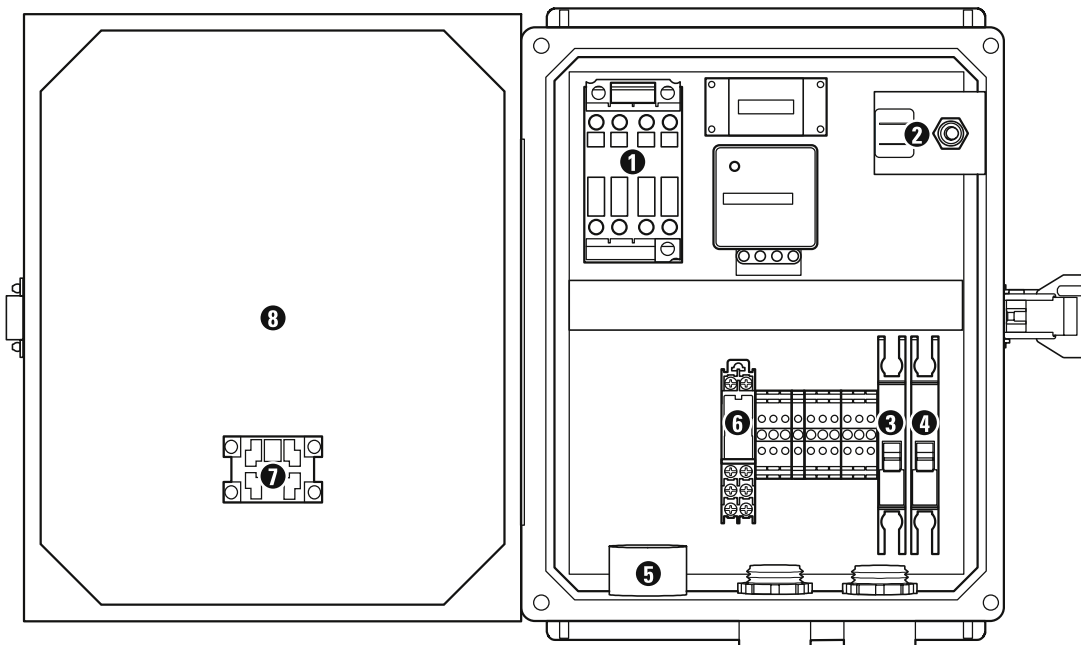

Orenco S-Series Simplex Control Panel (S1ETMCT shown)

Standard Features

Feature	Specifications (all voltages are 120 VAC unless otherwise noted)
1. Motor-start contactor	120 VAC: 17 FLA, 1 hp (0.75 kW), 2.5 million cycles at FLA 240 VAC: 17 FLA, 3 hp (2.24 kW), 2.5 million cycles at FLA
4. Auto/Off/Man toggle switch	Single-pole, double-throw HOA switch
2. Controls circuit breaker	10 A, OFF/ON switch, single pole, DIN rail mounting with thermal magnetic tripping characteristics
3. Pump circuit breaker	20 A, OFF/ON switch, single pole (120 VAC) or double pole (240 VAC), DIN rail mounting with thermal magnetic tripping characteristics
5. Audible alarm	95 dB at 24 in. (610 mm), warble-tone sound; gasketed, UL Type 4X (IP66)
6. Audible alarm silence relay	Automatic reset, DIN rail mount
7. Visible alarm	7/8-in. (22-mm) diameter red lens, "Push-to-silence," UL Type 4X (IP66), 1 W LED light
8. Enclosure	UV-resistant fiberglass and stainless steel, UL Type 4X (IP66)

Optional Features

Feature	Specifications (all voltages are 120 VAC unless otherwise noted)	Product code adder
Intrinsically safe control relays	Listed per UL 698A, for Class 1 Div. 1, groups A, B, C, D hazardous locations (Requires larger enclosure)	IR
Programmable timer	Repeat cycle from 0.05 seconds to 30 hours; separate variable controls for OFF & ON time periods	PT
Redundant off relay	DIN rail mount; provides a secondary off; sounds alarm upon low level condition	RO
Disconnect switch	120 VAC or 240 VAC; switch configuration is dependent on voltage and amperage	DS
Elapsed time meter	7-digit, non-resettable; limit of 99,999 hours; accurate to 0.01 hours	ETM
Event counter	6-digit, non-resettable	CT
Heater	anti-condensation heater; self-adjusting: radiates additional wattage as temperature drops	HT
Pump run light	7/8-in. (22-mm) diameter green lens; UL Type 4X (IP66), 1 W LED light	PRL
Power light	7/8-in. (22-mm) diameter green lens; UL Type 4X (IP66), 1 W LED light	PL
Surge arrestor	Status light on unit; protects incoming power supply from electrical surges	SA

MVP-Duplex Control Panel

Applications

Orenco's MVP-Duplex control panel has a dual-mode feature, making it ideal for both timed- and demand-dosing in two-pump alternating systems. All MVPs include an easy-to-use, programmable logic unit that incorporates many timing and logic functions, such as multiple timing intervals to adjust for changing flow conditions and a built-in elapsed time meter and counter.



The programmable logic unit is the brain of the MVP-Duplex control panel



Orenco® MVP-DAX1DM control panel accommodates both timed- and demand-dosing applications



Features/Unique Specifications

To specify this panel for your installation, require the following:

- Programmable for timed- or demand-dosing applications
- Built-in elapsed time meter and counters
- Digital timed-dose function accurate within 1%
- Multiple timer settings for optimum dosing during normal and peak flow conditions
- Pump alternation continues during override conditions
- Built-in programming keys for field-adjustable timer settings without a portable computer
- Ability to use EEPROM card to change panel functions
- High- and low-level alarm conditions differentiated by steady or blinking LED light
- Silenced alarms automatically reactivated after 12 hours if condition is not corrected
- Standard 120 VAC output for remote alarm activation
- Timed delays on float inputs to prevent chattering
- Ability to use one model of float for all functions
- Visual indicators of float positions
- Redundant-off function as standard
- UL 508 listing in US and Canada

Standard Models

MVP-DAX1DM, MVP-DAX2DM

Product Code Diagram

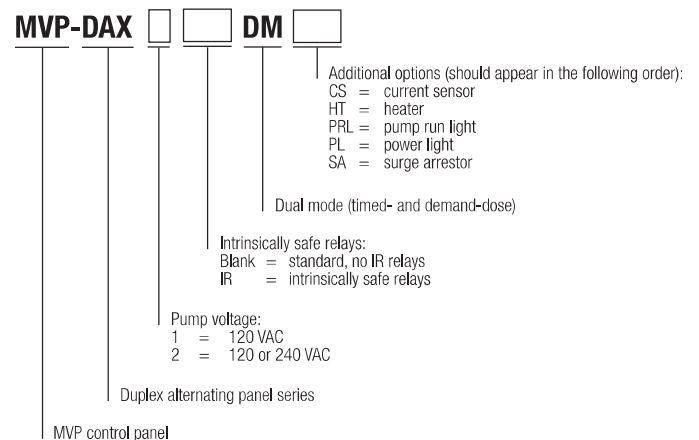

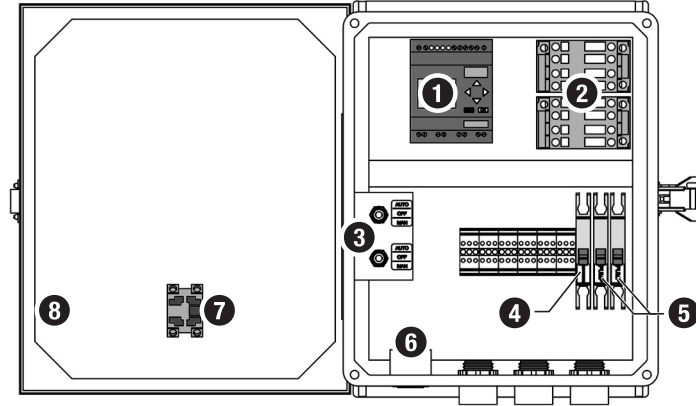

Orenco® MVP-DAX1DM 120 V panel

Standard Components

Feature	Specification(s)
1. Programmable Logic Unit	120 VAC programmable logic unit with built-in LCD screen and programming keys. Provides control functions and timing for panel operation.
2. Motor-Start Contactors	120 VAC: 16 FLA, 1 hp (0.75 kW), 60 Hz; 2.5 million cycles at FLA (10 million at 50% of FLA) 240 VAC: 16 FLA, 3 hp (2.24 kW), 60 Hz; 2.5 million cycles at FLA (10 million at 50% of FLA)
3. Toggle Switches	Single-pole, double-throw HOA switch. 20 A, 1hp (0.75 kW).
4. Controls Circuit Breaker	10 A, OFF/ON switch. Single-pole 120 V*. DIN rail mounting with thermal magnetic tripping characteristics.
5. Pump Circuit Breakers	20 A, OFF/ON switches. Single-pole 120 V or double-pole 240 V. DIN rail mounting with thermal magnetic tripping characteristics.
6. Audible Alarm	95 dB at 24 in. (610 mm), warble-tone sound.
7. Visual Alarm	7/8-in. (22-mm) diameter red lens, "Push-to-silence." UL Type 4X rated, 1 W LED light, 120 VAC.
8. Panel Enclosure	Measures 11.5 in. high × 9.5 in. wide × 5.4 in. deep (290 × 240 × 135 mm). UL Type 4X rated. Constructed of UV-resistant fiberglass; hinges and latch are stainless steel. Conduit couplings provided.
Dual-Mode Operation	Programmable for timed- and demand-dosing.
MVP-DAX1DM Panel Ratings	120 VAC, 1 hp (0.75 kW), 16 A, single phase, 60 Hz.
MVP-DAX2DM Panel Ratings	240 VAC, 3 hp (2.24 kW), 16 A, single phase, 60 Hz.

Optional Components

Feature	Specification(s)	Product Code Adder
Intrinsically Safe Control Relays	120 VAC. Listed per UL 698A, for Class 1 Div. 1, Groups A, B, C, D hazardous locations. Larger enclosure required.	IR
Current Sensor	120 VAC. Go/no-go operation. Pump fail indicator light on panel. Manual reset switch.	CS
Heater	Anti-condensation heater. Self-adjusting; radiates additional wattage as temperature drops.	HT
Pump Run Lights	7/8-in. (22-mm) diameter green lens. UL Type 4X rated, 1 W LED light, 120 VAC.	PRL
Power Light	7/8-in. (22-mm) diameter green lens. UL Type 4X rated, 1 W LED light, 120 VAC.	PL
Surge Arrestor	120 V. Status light on unit. Protects incoming power supply from electrical surges.	SA

* 240 VAC units available for int'l markets

** 120 VAC output for remote alarms comes standard.

Prelos™ Sewer

Prelos™ Processor On-Lot Package (Extended Pump)

L I M I T E D W A R R A N T Y

Commitment to Quality

Since 1981, Orenco Systems®, Incorporated (herein-after referred to as "Orenco"), has been known as a company that researches, designs, manufactures, and sells the highest-quality products. Prelos™ is the modern Pressurized Liquid-Only Sewer, a culmination of four decades of Orenco's proven community sewer solutions. At the core of the system is the Prelos Processor, a complete, integrated package that provides on-lot wastewater storage, filtration, and pumping to the pressurized liquid-only sewer.

Any wastewater system can be affected by improper design or installation, lack of maintenance, or system abuse. Although our products are carefully designed and constructed, it's still important to pay strict attention to system design and installation instructions and to follow through with intelligent usage and regular maintenance.

Limited Warranty Coverage

Subject to the exclusions, limitations, and conditions contained herein, Orenco warrants to the purchaser and subsequent owners, for a period of time corresponding to the type of product (the "Warranty Period," as listed below), that all of the component products comprising a Prelos Processor will be free from defects in materials or workmanship that cause the product to lose structural integrity or to electrically or mechanically operate improperly.

- (a) For Orenco multiple-stage, high-head, submersible turbine effluent pumps, the Warranty Period will be for ten years from the date of manufacture.
- (b) For all other component products, the Warranty Period will be for five years from the date of installation.

If Orenco determines that a Prelos Processor component has failed within the Warranty Period because of a defect in materials or workmanship, Orenco will repair or replace, at its discretion, the failed component.

Obtaining Warranty Service

To make a claim under this Limited Warranty, directly contact your Orenco Commercial and Municipal Wastewater Systems Dealer or Supplier ("Orenco's Representative"), who will process your claim. If for some reason Orenco's Representative is unavailable, or if you purchased your Prelos Processor directly from Orenco, contact Orenco by phone (800-348-9843 or +1-541-459-4449) to make your claim.

Any warranty claim must be received no later than the expiration of the Warranty Period listed above.

If requested by Orenco, potentially defective components must be returned to Orenco's Sutherlin, Oregon facility through Orenco's Representative, if applicable, transportation prepaid.



Exclusive Remedy

The exclusive remedy for any claim under this Limited Warranty shall be the obligation of Orenco to repair or exchange, at its discretion, any defective components. Except for Orenco staff time spent repairing or exchanging a defective component, any and all labor expenses associated with identifying, removing, shipping, repairing, or replacing defective components are not covered under this Limited Warranty. Defects in materials or workmanship will be determined in good faith by Orenco upon receipt and inspection of a returned component. Components shall not be deemed to be defective if the failure, malfunction, or damage was caused by, or resulted from:

- (a) the Prelos Processor not being designed properly for the application in accordance with Orenco's design criteria or not being installed in accordance with said design;
- (b) abuse, misuse, accident, or negligence;
- (c) a catastrophic event beyond the control of Orenco; or
- (d) improper or incorrectly performed installation, maintenance, repair, or modification of any component of the Prelos Processor.

In the event Orenco determines that a returned component is defective in materials or workmanship and covered by this Limited Warranty, Orenco will credit or reimburse you for all reasonable transportation charges incurred in returning the component, and will be responsible for all transportation charges to return the repaired or exchanged component to you. The Warranty period for such repaired or exchanged component shall toll from the original purchase. In the event Orenco determines that a returned component is not defective in materials or workmanship, or is not covered by this Limited Warranty, Orenco may charge you a testing fee and all reasonable transportation charges required to return the component to you.

IN EXCHANGE FOR THE WARRANTY COVERAGE, PURCHASER AND SUBSEQUENT OWNERS AGREE THAT ORENCO WILL NOT BE LIABLE FOR ANY LOSS, INJURY, OR DAMAGES TO PERSONS OR PROPERTY RESULTING FROM FAILURE OF, OR ANY DEFECT IN, THE PRELOS PROCESSOR, OR FOR ANY TECHNICAL ASSISTANCE OR INFORMATION THAT ORENCO MAY HAVE PROVIDED TO THE OWNER. NOR SHALL ORENCO BE LIABLE FOR ANY INCIDENTAL, CONSEQUENTIAL, SPECIAL, OR INDIRECT DAMAGES OF ANY KIND, INCLUDING, BUT NOT LIMITED TO, LOSS OF PROFITS, PLANT DOWNTIME, FINES OR PENALTIES, OR LAWSUITS BY THIRD PARTIES AGAINST THE PRELOS PROCESSOR OWNER OR LOT OWNER. IN NO EVENT SHALL THE LIABILITY OF ORENCO UNDER THIS LIMITED WARRANTY EXCEED THE TOTAL INVOICED PRICE, EXCLUDING INSTALLATION AND/OR STARTUP COSTS, OF THE PRELOS PROCESSOR.

Disclaimer

EXCEPT AS SPECIFIED IN THIS LIMITED WARRANTY, ALL EXPRESS OR IMPLIED CONDITIONS, REPRESENTATIONS, AND WARRANTIES INCLUDING, WITHOUT LIMITATION, ANY IMPLIED WARRANTY OR CONDITION OF MERCHANTABILITY, FITNESS FOR A PARTICULAR PURPOSE, SATISFACTORY QUALITY, ACCURACY OF INFORMATIONAL CONTENT, OR THOSE ARISING FROM A COURSE OF DEALINGS, LAW, USAGE, OR TRADE PRACTICE, MAY ONLY BE CLAIMED DURING THE WARRANTY PERIOD, AND THEREAFTER ARE HEREBY EXPRESSLY DISCLAIMED AND EXCLUDED TO THE EXTENT ALLOWED BY APPLICABLE LAW.

Exclusions and Limitations

This Limited Warranty shall be void if any of the following occur:

- (a) construction or installation of the Prelos Processor is not performed in accordance with Orenco's published *Installation Instructions*;
- (b) components not provided or approved by Orenco are used in the installation, maintenance, or repair of the Prelos Processor;
- (c) settings or operation of pumps, metering devices, effluent distribution components or other parts that can affect the integrity and proper functioning of the Prelos Processor are changed without authorization from Orenco, Orenco's Representative, or an Authorized Commercial Operator; or
- (d) the Prelos Processor is not operated or maintained in accordance with the instructions contained in the *Operation and Maintenance Manual* provided by Orenco.

PPED Packages

Orenco DuraFiber™ FLD Access Lids

Applications

Orenco DuraFiber FLD Access Lids provide secure, durable, watertight coverings for ribbed PVC, HDPE, and Orenco FRP risers, pump basins, and access ports. They are capable of supporting a 2500lb (1134kg) load; however, they are not recommended for vehicular traffic.

FLD24 24in (600mm) lids require an RLA24 adapter to connect to Perma-Loc™ pipe. FLD30 30in (750mm) lids are not compatible with RLA30 Riser-Lid-Adapters or 30in (750mm) Perma-Loc pipe.

General

DuraFiber FLD lids are designed for extreme durability and damage resistance, with UV- and corrosion-resistant materials, optional EPDM gaskets for watertight lid-to-riser connections, and flat-style flanges for easy access with clean, flush-to-grade installations. They also have centering rings for easy alignment. FLD lids feature a non-skid surface and a molded-in caution statement, with room for a customer logo. All come with four 5/16in stainless steel socket cap screws and a hex key wrench.

FLD lids are available with optional insulation, installed at the factory or in kits that can be installed in the field.

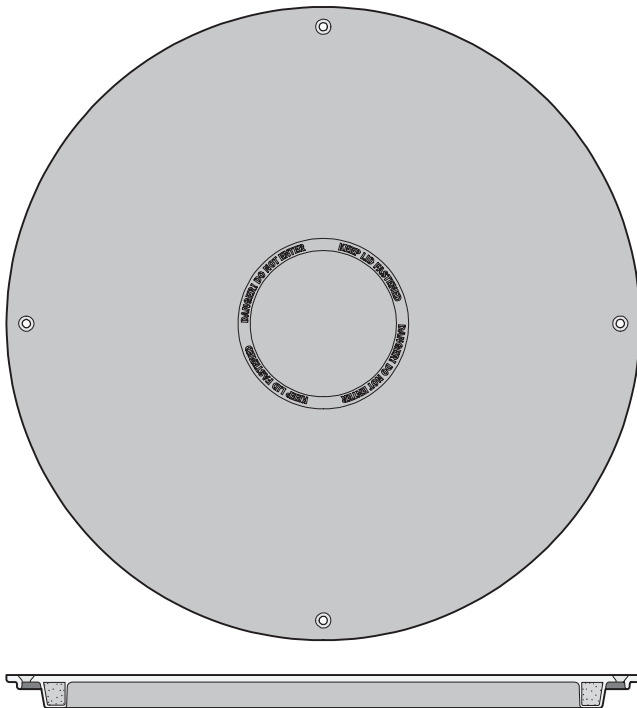

DuraFiber FLD lid: top view and side-cutaway view

Standard Models

FLD18G, FLD24G, FLD24G-ATX, FLD24G-W, FLD30G, FLD30G-ATX, FLD30G-PRELOS, FLD30G-W

Product Code Diagram

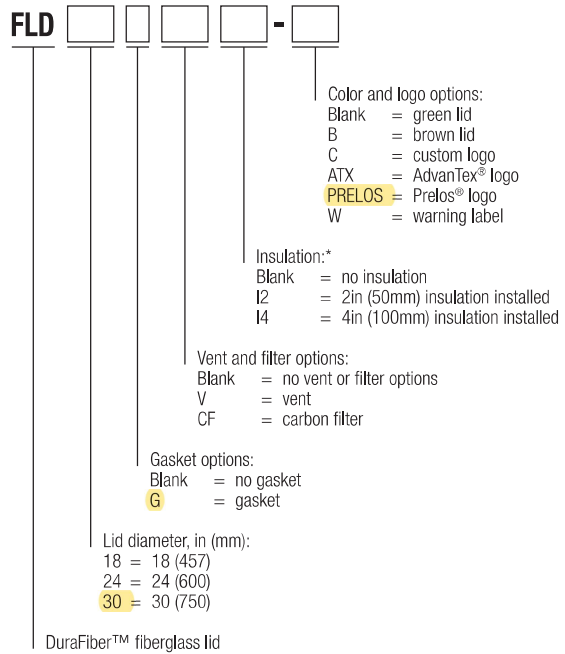

*Insulation has an R-value of 10 per 2in (RSI of 1.8 per 50mm) increment

Materials of Construction

Lid	Fiber-reinforced polymer (FRP)
Gasket (FLD18)	Urethane
Gasket (FLD24, FLD30)	EPDM
Centering ring core	Structural foam
Mounting hardware	Stainless steel
Insulation, optional	Closed-cell foam
Insulation mounting hardware	Stainless steel

Specifications

Model	FLD18XX	FLD24XX	FLD30XX
A in (mm)	20.2 (514)	25.75 (654)	32.75 (832)
B in (mm)	1.5 (38)	1.5 (38)	1.5 (38)
C in (mm)	17.5 (445)	23.25 (591)	29.25 (743)
Insulation R-value per 2in (RSI per 50mm) increment	10 (1.8)	10 (1.8)	10 (1.8)
Gasket width, in (mm)	0.75 (19)	0.69 (18)	0.69 (18)
Bolt hole diameter, in (mm)	0.3125 (8)	0.3125 (8)	0.3125 (8)
Weight, lbs (kg)	7 (3)	11 (5)	20 (9)
Bolt holes per lid	4	4	4

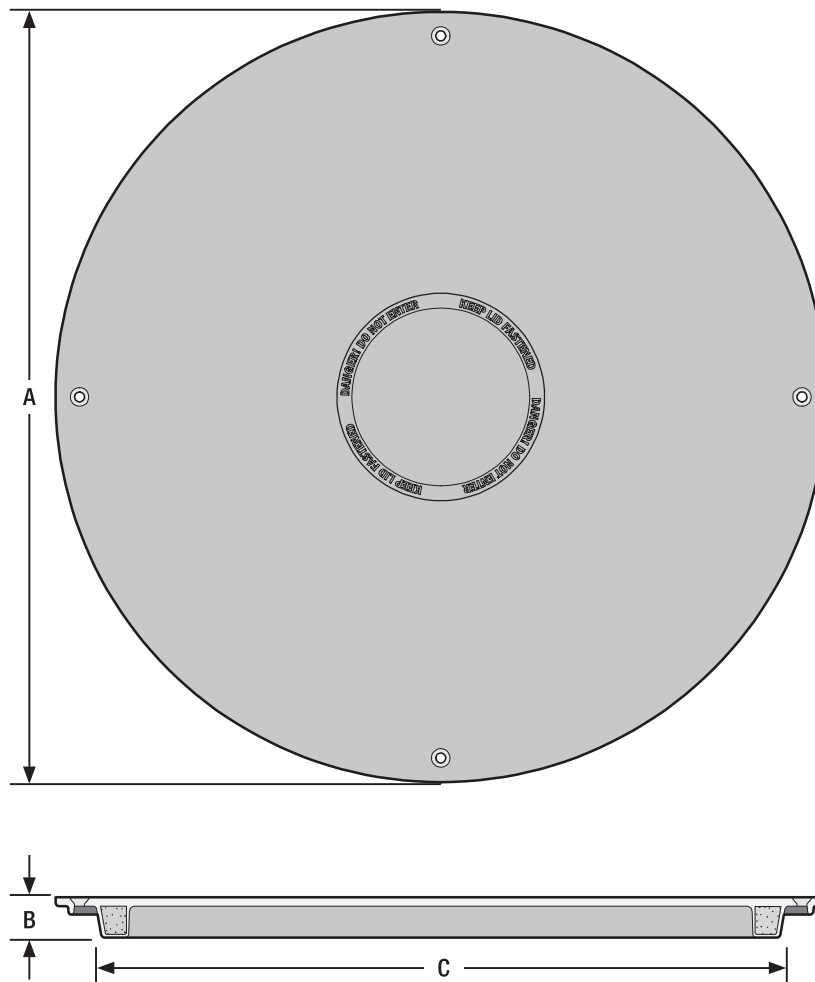

PRTA ABS Tank Adapters

Applications

PRTA tank adapters are used to provide a structural, watertight method of installing a 24- or 30-inch (600- or 750-mm) access riser over a tank opening.

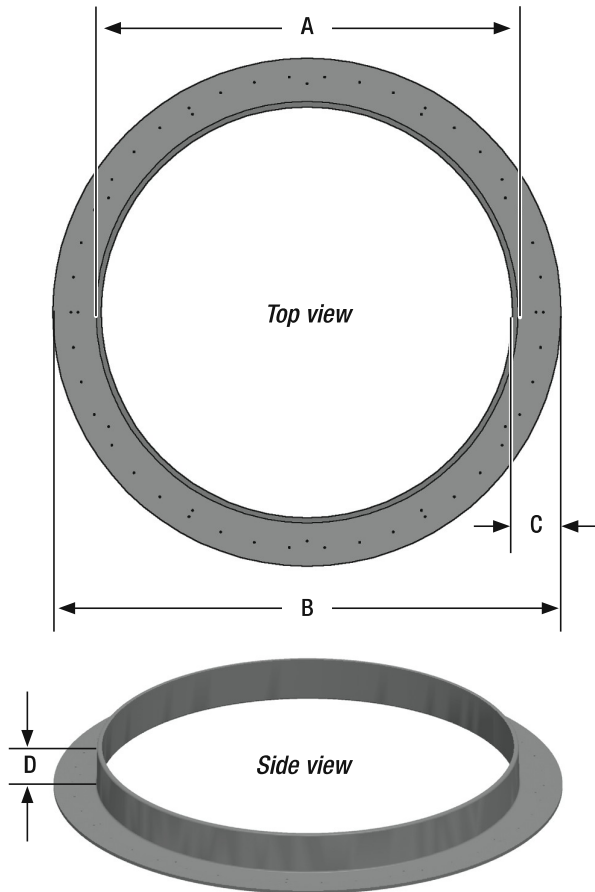

General

Orenco's PRTA tank adapters are molded plastic products and therefore have excellent part-quality and consistency. PRTA tank adapters can be cast into a tank or fastened to the top of the tank with a bolt-down kit. The bolt-down kit consists of either six or twelve (depending on model) stainless steel concrete anchors and a roll of butyl tape.

The O.D. of the vertical flange matches the I.D. of Orenco's ribbed risers, which provides a suitable joint to seal with MA320 or ADH200 adhesive.

Standard Models

PRTA24, PRTA30

PRTA24BDKIT (6 anchors), PRTA30BDKIT (12 anchors)

Product Code Diagram

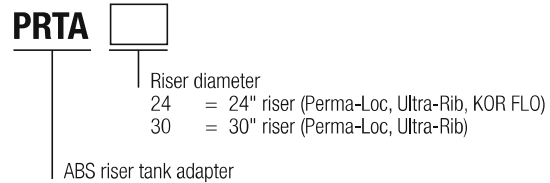

Materials of Construction

Tank adapter	ABS
Concrete anchors	Stainless steel anchor bolts
Sealant	Butyl tape

Specifications

Dimensions*	PRTA24	PRTA30
A - Outside dia., in. (mm)	23.38 (594)	29.25 (743)
B - Flange dia., in. (mm)	26.75 (679)	34.25 (870)
C - Horizontal flange width, in. (mm)	2.00 (51)	2.50 (64)
D - Vertical flange height, in. (mm)	3.50 (89)	3.25 (83)

*The tank adapter has a nominal 0.25 inch (6 mm) thickness.

Adhesives and Dispensers for Orenco Products



MA8120-300/300



SA510-300/300



MA320



IPS 810



ADH200



MA-MANUAL GUN-600ML



MA-BATT GUN-600ML

Applications

Orenco adhesives and dispensers are used to create durable, water-tight bonds between tanks, risers, and adapters, as well as between grommets and risers.

General

When working with Orenco products, use only approved adhesives. Before using an adhesive not listed in this document, contact Orenco or your distributor.

Check the expiration date on adhesive packages. If the adhesive is expired, do not use it to install Orenco components.

Structural Methacrylate Adhesives

MA8120 and SA510

MA8120 and SA510 are two-component methacrylate structural adhesives. They are used to bond ABS, DCPD, FRP, and PVC for strong, watertight joints. They will not bond to concrete. Clean, dry bonding surfaces are required for proper adhesion.

MA8120 is intended for applications requiring a long working time or for thicker adhesive bead lines; it will sag slightly in warm temperatures. SA510 is intended for applications requiring a short working time or for thinner adhesive bead lines. Both have a 1:1 mix ratio.

MA320

MA320 is a two-component methacrylate adhesive. It is used to bond ABS, FRP, and PVC for strong, watertight joints. It will not bond to concrete. Clean, dry bonding surfaces are required for proper adhesion. MA320 requires hand mixing.

IPS 810

IPS 810 is a self-leveling, two-component methacrylate adhesive, used to bond ABS, FRP, PVC, and concrete for strong, watertight joints. Clean, dry bonding surfaces are required for proper adhesion. IPS 810 requires hand mixing. Pint (product code ADHP10) or quart (product code ADHPQ10) quantities are available.

Sealant/Adhesive

ADH200

ADH200 is a moisture-curing, single-component adhesive/sealant used for sealing pipe grommets and for joining PVC or FRP risers to ABS or FRP tank adapters where joints are in shear. It is designed for applications in damp, dry, or cold climates. It is solvent free and contains no isocyanates. ADH200 will not shrink upon curing and will not discolor when exposed to UV light. Clean, dry bonding surfaces are required for proper adhesion. It is not intended for structural joints that are primarily in tension, in peel, or in bending.

Adhesives Specifications

	MA8120	SA510	MA320	IPS 810	ADH200
Applications	Bonds ABS, DCPD, FRP, PVC; for longer working times or thicker adhesive beads	Bonds ABS, DCPD, FRP, PVC; for shorter working times or thinner adhesive beads	Bonds ABS, FRP, PVC	Self-leveling; bonds ABS, concrete, FRP, PVC	Shear joints (PRTA-style adapters; adheres and seals pipe grommets, fasteners, etc.)
Color	Grey	Grey	White	White	White
Working Time @ 70°F (21°C)	~ 20min	10-15min	10-20min	~ 10min	n/a; 35 min (+/- 10 min) tack-free time
Cure Time @ 70°F (21°C)	< 2hr, depending on ambient temperature and adhesive bead/joint thickness	< 45min, depending on ambient temperature and adhesive bead/joint thickness	~ 1hr, depending on ambient temperature and adhesive bead/joint thickness	~ 2hr, depending on ambient temperature and adhesive bead/joint thickness	Handling strength in 12hrs; full cure in 2-3 days
Unit Quantities	300/300mL cartridge (600mL total)	300/300mL cartridge (600mL total)	7oz (200mL) packet	1pt (473mL) 1qt (946mL)	10.2oz (300mL) tube
Shelf Life	See "use by" date on cartridge	See "use by" date on cartridge	1yr from oldest date code shown on product	1yr from date shown on product	12mo from mfg date at 70°F (21°C) with 50% relative humidity
Dispensing Guns	MA-BATT GUN-600ML, MA-MANUAL GUN-600ML	MA-BATT GUN-600ML, MA-MANUAL GUN-600ML	None, hand mix in packet	None, hand mix in jar	Standard caulking gun

Approximate Quantities of Adhesive Needed, by Product

	MA8120	SA510	MA320	IPS 810	ADH200
FRTA24-RVF Adapter, 24in (600mm)	½ cartridge*	½ cartridge*	1-2 packets	n/a	1 tube
PRTA24 Adapter, 24in (600mm)	½ cartridge*	½ cartridge*	1-2 packets	n/a	1 tube
PRTA24-2 Adapter, 24in (600mm)	> ½ cartridge*	> ½ cartridge*	n/a	< 1pt	n/a
PRTA30 Adapter, 30in (750mm)	< 1 cartridge*	< 1 cartridge*	2 packets	n/a	< 2 tubes
RRFTA Adapter, 24in (600mm)	< 1 cartridge*	n/a	n/a	1pt	n/a
RRFTA30 Adapter, 30in (750mm)	1 cartridge*	n/a	n/a	1qt	n/a
GR24XX Grade Ring, 24in (600mm)	½ cartridge*	½ cartridge*	1-2 packets	n/a	1 tube
GR30XX Grade Ring, 30in (750mm)	< 1 cartridge*	< 1 cartridge*	2 packets	n/a	< 2 tubes
Grommets	n/a	n/a	n/a	n/a	various quantities

* Indicates a preferred adhesive for this application

Universal Biotube® Pump Vaults

For use with Orenco® 4-inch (100-mm) Submersible Effluent Pumps

Applications

Orenco Biotube® Pump Vaults are used to filter effluent that is pumped from septic tanks or separate dosing tanks in STEP systems and onsite wastewater treatment systems. They remove two-thirds of suspended solids, on average. Pump vaults house a Biotube effluent filter and one or two Orenco high-head effluent pumps and can be used in single-compartment septic tanks with flows up to 40 gpm (2.5 L/sec). When flows are greater than 40 gpm (2.5 L/sec), a double-compartment septic tank or separate dosing tank is recommended.

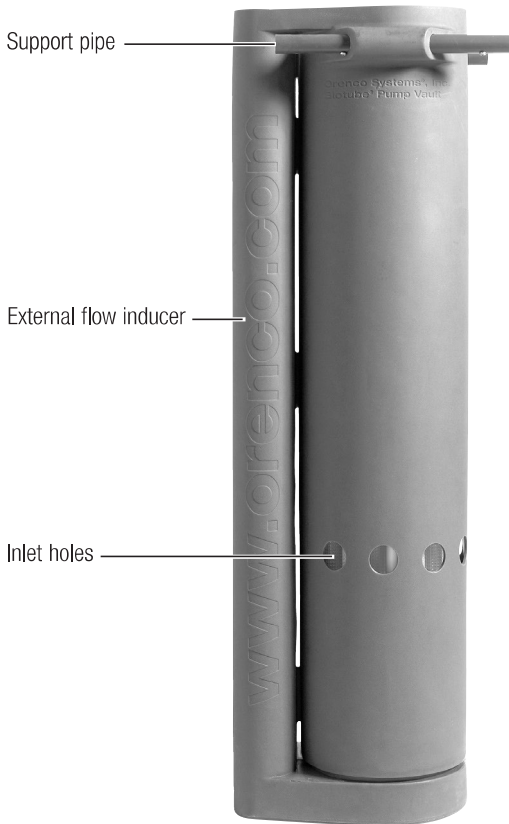

Side view

General

The Orenco Biotube Pump Vault includes a molded polyethylene housing with an internal Biotube filter cartridge constructed of polypropylene and PVC. Schedule 80 PVC support pipes are included to suspend the vault in a tank opening. “Earless” 68-inch (1727-mm) vaults, which rest on the bottom of the tank instead of on support pipes, are also available. The filter cartridge can be removed without pulling the pump or the vault. Effluent enters through inlet holes around the perimeter of the Biotube vault and flows through the Biotubes to the external flow inducer. The external flow inducer accommodates one or two pumps. Orenco Biotube Pump Vaults are covered by U.S. patents #4,439,323 and 5,492,635.

Standard Models

PVU48-1818, PVU57-1819, PVU68-2419, PVU84-2419, PVU95-3625

Product Code Diagram

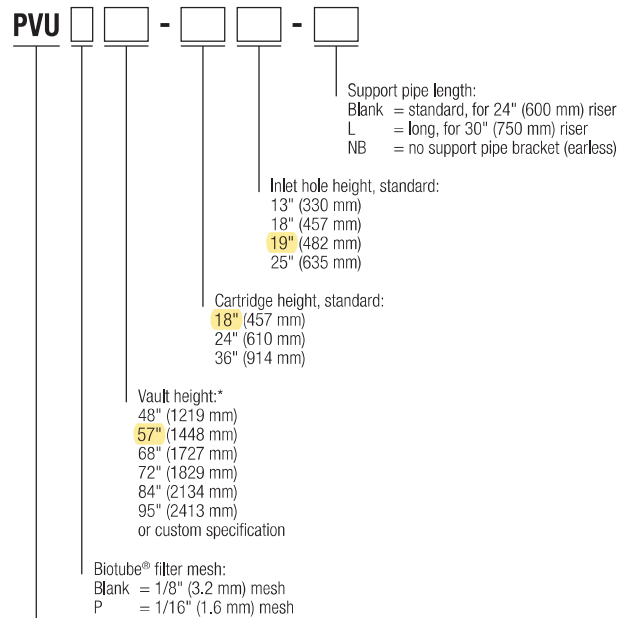

Universal Pump Vault

* Custom heights from 42" to 135" available

Tank Access and Riser Diameters

Diameter, in. (mm)	PVU with simplex pump	PVU with duplex pumps
Tank access, minimum	19 (483)	19 (483)
Tank access, recommended	20 (508)	20 (508)
Riser, minimum	24 (600)	30 (750)

Materials of Construction

Support pipe	Schedule 80 PVC
Biotube® vault	Polyethylene
Biotube filter cartridge	Polypropylene/PVC
Float stem	Schedule 40 PVC
Drain valve ball	Polypropylene

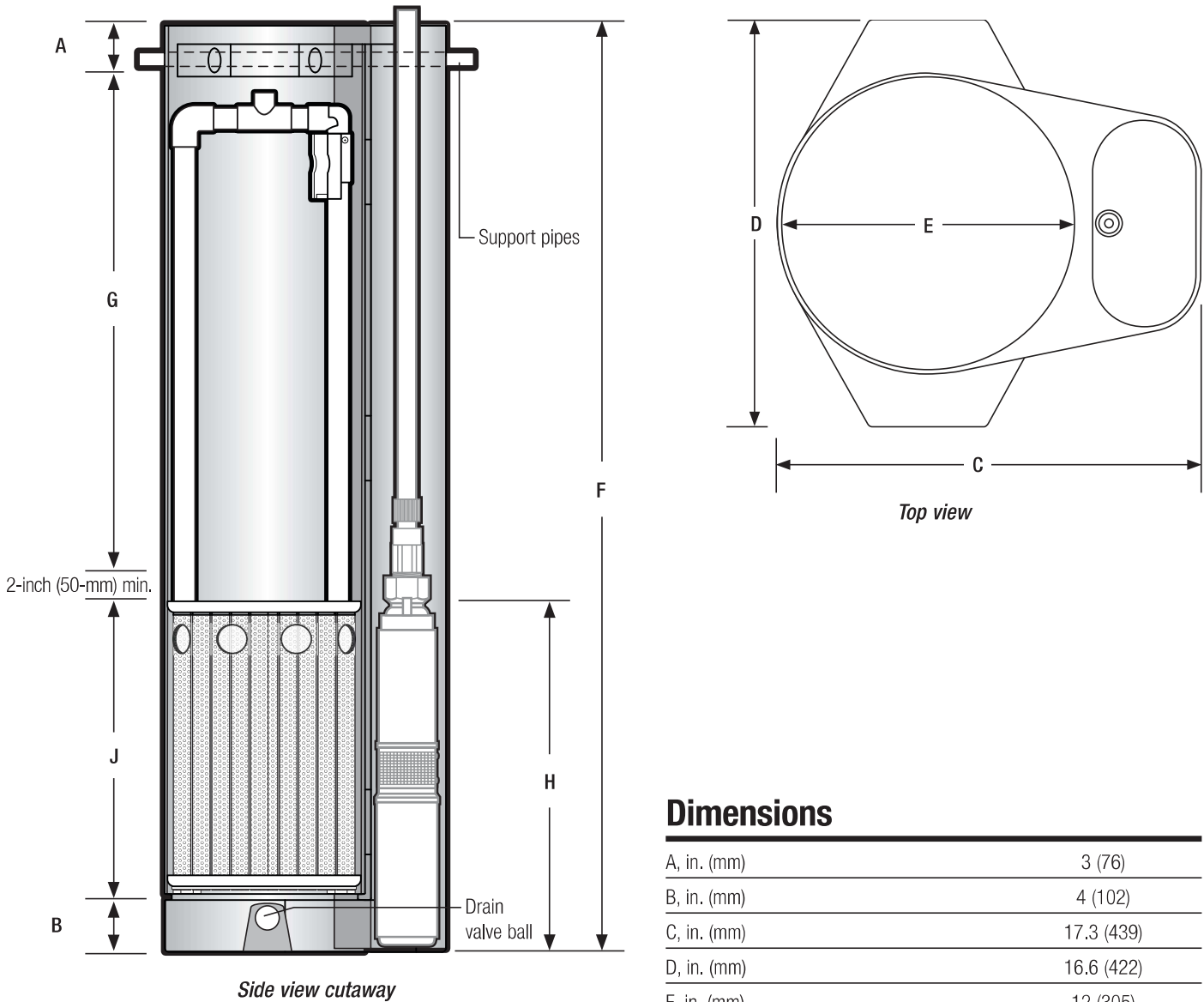

Dimensions

A, in. (mm)	3 (76)
B, in. (mm)	4 (102)
C, in. (mm)	17.3 (439)
D, in. (mm)	16.6 (422)
E, in. (mm)	12 (305)

Specifications

Model	PVU48-1818	PVU57-1819	PVU68-2419	PVU84-2419	PVU95-3625
F, vault height, in. (mm)	48 (1219)	57 (1448)	68 (1727)	84 (1727)	95 (2413)
G, lowest float setting point, in. (mm)	21 (533)	29 (737)	35 (889)	51 (1295)	50 (1270)
H, inlet hole height, in. (mm)*	18 (457)	19 (483)	19 in. (483)	19 (482)	25 (635)
J, Biotube® cartridge height, in. (mm)	18 (457)	18 (457)	24 (610)	24 (610)	36 (914)
Biotube mesh opening, in. (mm)	0.125 (3)	0.125 (3)	0.125 (3)	0.125 (3)	0.125 (3)
Filter flow area, ft ² (m ²)	4.4 (0.4)	4.4 (0.4)	5.9 (0.5)	5.9 (0.5)	9.0 (0.84)
Filter surface area, ft ² (m ²)	14.5 (1.35)	14.5 (1.35)	19.7 (1.83)	19.7 (1.83)	30 (2.79)
Maximum flow rate, gpm (L/sec)	140 (8.8)	140 (8.8)	140 (8.8)	140 (8.8)	140 (8.8)

* May vary depending on the configuration of the tank.

Discharge Assemblies

Applications

Orenco Discharge Assemblies are used to convey effluent from a pump to the exterior of a riser or pump basin. They come in the following configurations:

- High head, for use with submersible turbine pumps
- Low head, for use with common effluent pumps
- Drainback, for use with shallowly buried tanks and transport lines in cold climates
- Two additional applications are available:
- The cold weather kit coupled with a high-head discharge assembly is intended for use with deeply buried tanks and transport lines in cold weather
- The external flex extension is recommended for installations where tank settling may occur to avoid line breakage during settling.

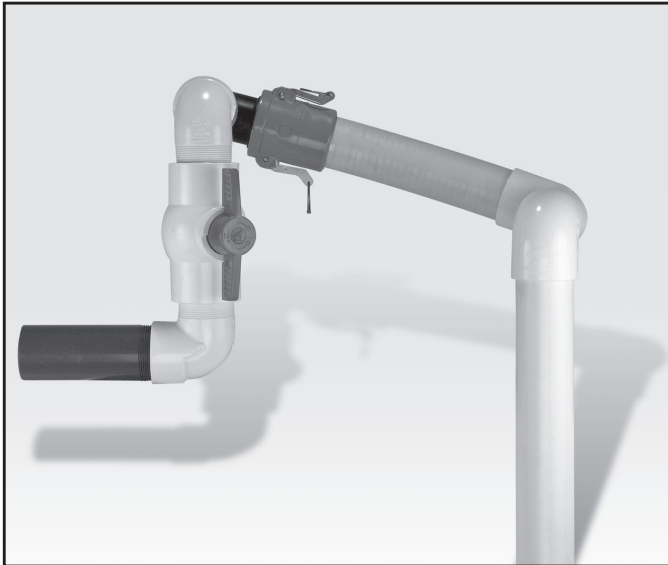

High head style shown with optional quick-disconnect

General

Orenco Discharge Assemblies are corrosion-resistant and adjustable for a proper fit. Discharge assemblies are composed of PVC valves and flexible hose that simplify installation and maintenance. The flexible hose damps vibrations from the pump and allows for easy installation. Cam-style quick-disconnect fittings are available on all configurations. All parts are either solvent welded or threaded and sealed with Teflon[®] paste.

Teflon[®] is a registered trademark of DuPont.

Standard Models

HV100, HV125, HV150, HV200

Product Code Diagram

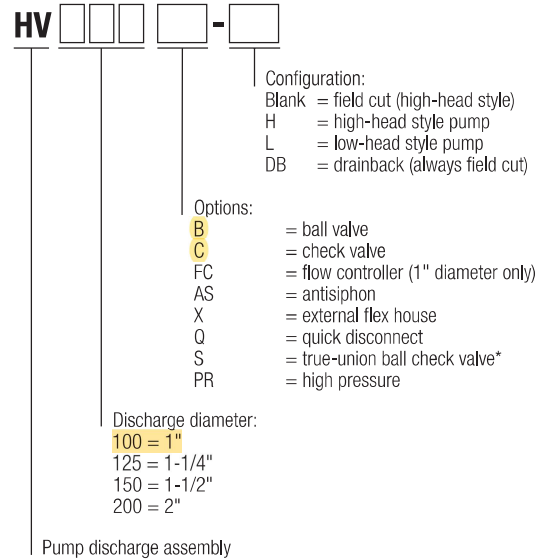

* Available for 1-1/2" discharge only

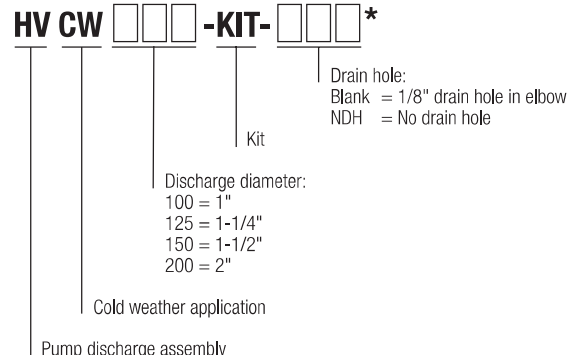

* Always ordered with high head discharge assembly

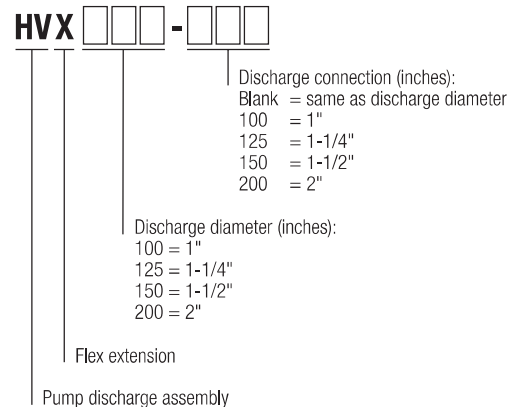

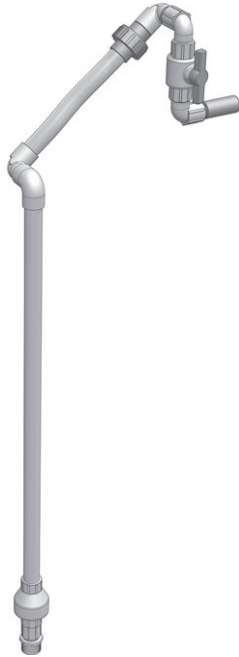

High head style



Drainback style



Low head style

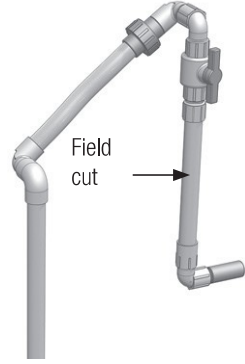

High head style with cold weather kit installed



Cold weather kit

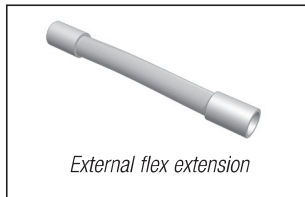

External flex extension

Component Working Pressure Ratings

True union ball check valve	200 psi (14 bar) at 73° F (23° C)
All other valves	150 psi (10 bar) at 73° F (23° C)
Unions	150 psi (10 bar) at 73° F (23° C)

Materials of Construction

Component	Material
Anti-siphon valve	Schedule 40 PVC
Ball valve	Schedule 40 PVC
Check valve	Schedule 40 PVC
Pipe and fittings	Schedule 40 PVC
Flexible hose	PVC
External flex hose	PVC
Flow control disc	Schedule 80 PVC
Gate valve	Schedule 80 PVC
Unions	Schedule 80 PVC
High-pressure flex hose	Special elastomer compound

Hose Specifications

Thickness and working pressures at 73° F (23° C)

Flexible hoses	Size (U.S. Nominal)	Wall thickness	Working pressure	Bursting pressure
(standard and external)	1 in.	0.11 in. (2.8 mm)	100 psi (7 bar)	355 psi (24 bar)
	1.25 in.	0.13 in. (3.3 mm)	80 psi (6 bar)	250 psi (17 bar)
	1.5 in.	0.13 in. (3.3 mm)	65 psi (4 bar)	200 psi (14 bar)
	2 in.	0.16 in. (4.1 mm)	60 psi (4 bar)	175 psi (12 bar)
Flexible hoses	Size (U.S. Nominal)	Wall thickness	Working pressure	Bursting pressure
(high-pressure)	1 in.	0.235 in. (6.0 mm)	250 psi (17 bar)	N/A
	1.25 in.	0.24 in. (6.1 mm)	250 psi (17 bar)	N/A
	1.5 in.	0.24 in. (6.1 mm)	250 psi (17 bar)	N/A
	2 in.	0.22 in. (5.6 mm)	200 psi (14 bar)	N/A

External Splice Box

Applications

The Orenco® External Splice Box attaches outside the access riser of an underground tank. It's engineered specifically for water and wastewater treatment systems and is especially suited for use in locations prone to high groundwater and other wet conditions. Its separate conduit hubs, large volume, and optional dividers make it useful for maintaining isolation of high- and low-voltage wires, where needed. It has four cord grips, which accommodate power cords for floats and pumps of 0.170 - 0.470 inches (4.3 - 11.9 mm) in diameter. Unused cord grips can be plugged watertight with the supplied cord grip plugs. Each External Splice Box includes a riser adapter designed to provide a watertight connection between the splice box and riser.



The External Splice Box is molded PVC.
It has a UL Type 6P listing for prolonged submergence.

General

To specify the Orenco External Splice Box for your installation, require the following:

- Watertightness for prolonged submergence per UL listing (Type 6P)
- Attachment external to access riser to allow inspection with no need to open the riser lid
- Volume of 126 in.³ (2065 cm³) for easy wiring access and multiple wiring configurations
- Bottom entry, so conduit or direct-bury cable always remains below minimum burial depth
- UV-resistant rating for outdoor use
- Optional divider plates for isolating high- and low-voltage wires from separate conduits or direct-bury cable
- Included riser adapter to eliminate the need for a grommet

Standard Models

SBEX1-4, SBEX1-4-P

Product Code Diagram

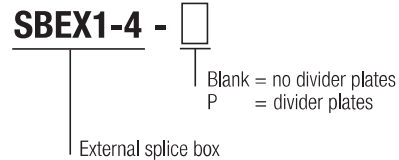

Physical Specifications

Volume	126 in. ³ (2065 cm ³)
Cord grips	4
Cord grip plugs	3
Cord diameters accommodated	0.170-0.470 in. (4.3-11.9 mm)
Conduit hubs	2
Conduit hub plug	1
Conduit sizes accommodated	½ in. (with fitting or bell end) ¾ in. 1 in. (with coupling)
Dia. of hole into riser	5 in. (127 mm); hole-cutting template included

Materials of Construction

Splice box	PVC
Cord grips	Nylon
Cord grip plugs	EPDM rubber
O-rings	Buna rubber
Conduit hub plug	PVC
Riser adapter	ABS



Orenco® PF-Series 60Hz, 1-Phase Pumps

Applications

Orenco's 60Hz, 1-phase, 4in (100mm) Submersible Effluent Pumps are designed to transport screened effluent (with low TSS counts) from septic or dosing tanks. These pumps are engineered using lightweight, corrosion-resistant stainless steel and polymers, and are field serviceable and repairable with common tools. They're also CSA and UL certified to US and Canadian safety standards for effluent pumps.

PF-Series pumps are used in a variety of applications, including pressurized drainfields, packed-bed filters, mounds, aerobic units, effluent irrigation, liquid-only (effluent) sewers, wetlands, lagoons, and more. These pumps are designed to be used with a Biotube® pump vault or after a secondary treatment system.



Powered by
Franklin Electric

General

To specify this pump for your installation, require the following:

- Minimum 24-hour run-dry capability (liquid end) with no deterioration in pump life or performance*
- 1/8in (3mm) bypass orifice to ensure flow recirculation for motor cooling and to prevent air binding
- 1/8in (3mm) mesh intake screen to limit solids
- Liquid-end repair kit availability for better long-term cost to own
- TRI-SEAL™ floating impeller design on 10, 20, and 30gpm (0.6, 1.3, and 1.9L/sec) models; floating stack design on 50 and 75gpm (3.2 and 4.7L/sec) models
- Franklin Electric Super Stainless motors are rated for continuous use and frequent cycling, with surge arrestors, hermetically sealed motor housing for moisture-free windings, and Kingsbury-type thrust bearing for thrust absorption
- Thermal overload protection trips at 203-221°F (95-105°C) for 1-phase motors through 1.5hp (1.12kW)
- Type SOOW 600V motor cable (model PF751512 uses 14 AWG, SJ00W, 300V cord)

* Not applicable for 5hp (3.73kW) models

Standard Models

See [Specifications on page 2](#) for a list of standard pumps. For a complete list of available pumps, call Orenco.

Product Code Diagram

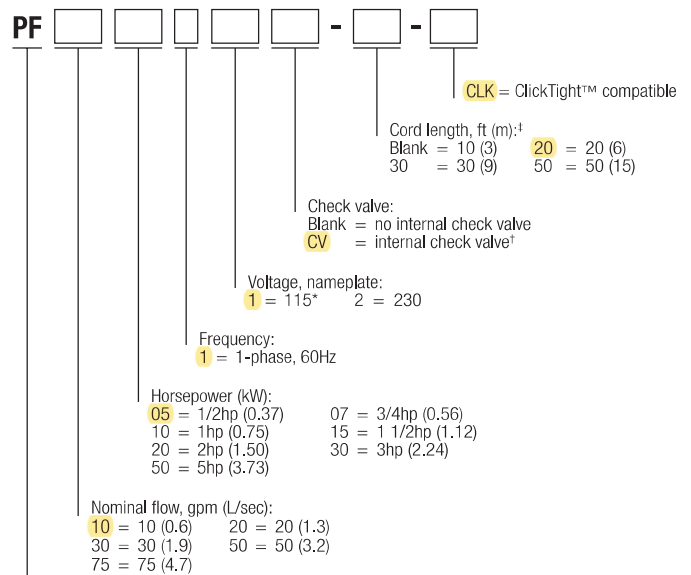

Pump, PF-Series

* 1/2hp (0.37kW) only

[†] Available for 10gpm (0.6L/sec), 1/2hp (0.37kW)

[†] Note: 20ft cords are available only for pumps through 1 1/2hp

Specifications

Pump Model	Design gpm (L/sec)	Horsepower (kW)	Phase	Nameplate voltage	Actual voltage	Design flow amps	Max amps	Discharge size and material ¹	Length in (mm)	Min. liquid level in (mm) ²	Weight lb (kg) ³	Rated cycles per day
PF100511 ⁹	10 (0.6)	0.50 (0.37)	1	115	120	12.7	12.7	1¼in GFP	23.0 (584)	16 (406)	26 (12)	300
PF100511CV ⁹	10 (0.6)	0.50 (0.37)	1	115	120	12.7	12.7	1¼in GFP	23.0 (584)	16 (406)	26 (12)	300
PF100512 ⁹	10 (0.6)	0.50 (0.37)	1	230	240	6.3	6.3	1¼in GFP	23.0 (584)	16 (406)	26 (12)	300
PF100712 ^{4,5,9}	10 (0.6)	0.75 (0.56)	1	230	240	8.3	8.3	1¼in GFP	25.9 (658)	17 (432)	30 (14)	300
PF101012 ^{5,6,9}	10 (0.6)	1.00 (0.75)	1	230	240	9.6	9.6	1¼in GFP	27.9 (709)	18 (457)	33 (15)	100
PF200511 ⁹	20 (1.3)	0.50 (0.37)	1	115	120	12.3	12.5	1¼in GFP	22.3 (566)	18 (457)	25 (11)	300
PF200512 ⁹	20 (1.3)	0.50 (0.37)	1	230	240	6.4	6.5	1¼in GFP	22.5 (572)	18 (457)	26 (12)	300
PF201012 ^{4,5,9}	20 (1.3)	1.00 (0.75)	1	230	240	10.5	10.5	1¼in GFP	28.4 (721)	20 (508)	33 (15)	100
PF201512 ^{4,5}	20 (1.3)	1.50 (1.12)	1	230	240	12.4	12.6	1¼in GFP	34.0 (864)	24 (610)	41 (19)	100
PF300511 ⁹	30 (1.9)	0.50 (0.37)	1	115	120	11.8	11.8	1¼in GFP	21.3 (541)	20 (508)	28 (13)	300
PF300512 ⁹	30 (1.9)	0.50 (0.37)	1	230	240	6.2	6.2	1¼in GFP	21.3 (541)	20 (508)	25 (11)	300
PF300712 ⁹	30 (1.9)	0.75 (0.56)	1	230	240	8.5	8.5	1¼in GFP	24.8 (630)	21 (533)	29 (13)	300
PF301012 ^{4,9}	30 (1.9)	1.00 (0.75)	1	230	240	10.4	10.4	1¼in GFP	27.0 (686)	22 (559)	32 (15)	100
PF301512 ^{4,5}	30 (1.9)	1.50 (1.12)	1	230	240	12.6	12.6	1¼in GFP	32.8 (833)	24 (610)	40 (18)	100
PF302012 ^{5,6,7}	30 (1.9)	2.00 (1.49)	1	230	240	11.0	11.0	1¼in SS	35.5 (902)	26 (660)	44 (20)	100
PF303012 ^{5,6,7,8}	30 (1.9)	3.00 (2.23)	1	230	240	16.8	16.8	1¼in SS	44.5 (1130)	33 (838)	54 (24)	100
PF305012 ^{5,6,7,8}	30 (1.9)	5.00 (3.73)	1	230	240	25.6	25.8	1¼in SS	66.5 (1689)	53 (1346)	82 (37)	100
PF500511 ⁹	50 (3.2)	0.50 (0.37)	1	115	120	12.1	12.1	2in SS	20.3 (516)	24 (610)	27 (12)	300
PF500512 ⁹	50 (3.2)	0.50 (0.37)	1	230	240	6.2	6.2	2in SS	20.3 (516)	24 (610)	27 (12)	300
PF500712 ⁹	50 (3.2)	0.75 (0.56)	1	230	240	8.5	8.5	2in SS	23.7 (602)	25 (635)	31 (14)	300
PF501012 ⁹	50 (3.2)	1.00 (0.75)	1	230	240	10.1	10.1	2in SS	27.0 (686)	26 (660)	35 (16)	100
PF501512 ⁴	50 (3.2)	1.50 (1.12)	1	230	240	12.5	12.6	2in SS	32.5 (826)	30 (762)	41 (19)	100
PF503012 ^{4,5,7,8}	50 (3.2)	3.00 (2.23)	1	230	240	17.7	17.7	2in SS	52.0 (1321)	37 (940)	55 (25)	100
PF505012 ^{5,6,7,8}	50 (3.2)	5.00 (3.73)	1	230	240	26.2	26.4	2in SS	77.0 (1956)	55 (1397)	64 (29)	100
PF751012 ⁹	75 (4.7)	1.00 (0.75)	1	230	240	9.9	10.0	2in SS	27.0 (686)	27 (686)	34 (15)	100
PF751512	75 (4.7)	1.50 (1.12)	1	230	240	12.1	12.3	2in SS	33.4 (848)	30 (762)	44 (20)	100

1. GFP = glass-filled polypropylene; SS = stainless steel. The 1 1/4in NPT GFP discharge is 2 7/8in octagonal across flats; the 1 1/4in NPT SS discharge is 2 1/8in octagonal across flats; and the 2in NPT SS discharge is 2 7/8in hexagonal across flats. Discharge is NPT threaded receptacle-style port, US nominal size, to accommodate Orenco discharge hose and valve assemblies. Consult your Orenco distributor about fittings to connect hose and valve assemblies to metric-sized piping.

2. Minimum liquid level is for single pumps when installed in an Orenco Biotube Pump Vault or Universal Flow Inducer. In other applications, minimum liquid level should be top of pump. Consult Orenco for more information.

3. Weight includes carton and 10ft (3m) cord.

4. High-pressure discharge assembly required.

5. Do not use cam-lock option (Q) on discharge assembly.

6. Custom discharge assembly required for these pumps. Contact Orenco.

7. Capacitor pack (sold separately or installed in a custom control panel) required for this pump. Contact Orenco.

8. Torque locks are available for all pumps, and they are supplied with 3hp and 5hp pumps.

9. ClickTight™ compatible.

Materials of Construction

Discharge	Glass-filled polypropylene or stainless steel
Discharge bearing	Engineered thermoplastic (PEEK)
Diffusers	Glass-filled PPO (SABIC's NORYL™ GFN3 resin)
Impellers	Celanese's Celcon® acetal copolymer on 10, 20, and 30gpm models; 50gpm impellers are NORYL GFN3 resin
Intake screen	Polypropylene
Suction connection	Stainless steel
Drive shaft	7/16in hexagonal stainless steel, 300 series
Coupling	Sintered stainless steel, 300 series
Shell	Stainless steel, 300 series
Motor	Franklin Electric motor filled with deionized water and propylene glycol for constant lubrication. Stainless steel shell.

Using a Pump Curve

A pump curve helps you determine the best pump for your system. Pump curves show the relationship between flow (gpm or L/sec) and pressure (total dynamic head or TDH), providing a graphical representation of a pump's optimal performance range. Pumps perform best at their nominal flow rate – the value, measured in gpm, expressed by the first two numerals in an Orenco pump nomenclature. These graphs use solid lines to show the optimal pump operation range. Dashed lines indicate flow rates outside of the optimal range for each pump. For the most accurate pump specifications, use Orenco's PumpSelect™ software.

Pump Curves

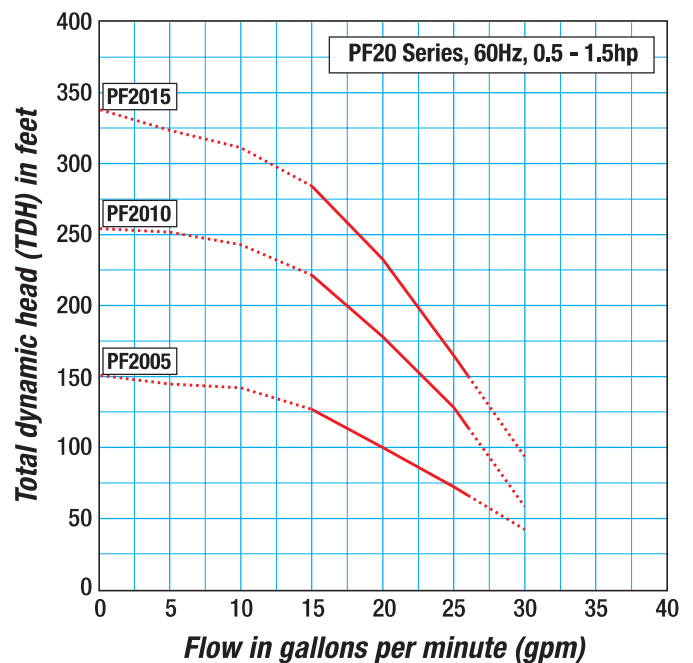
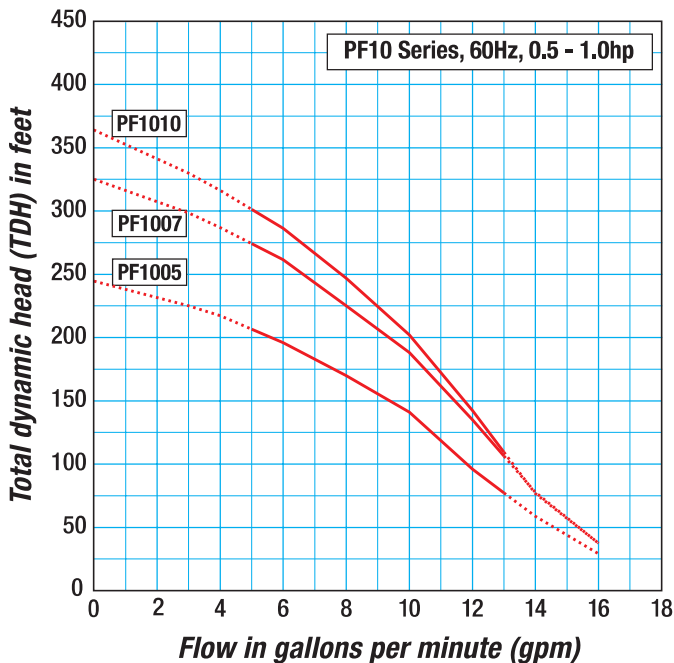

Pump Curves, cont.

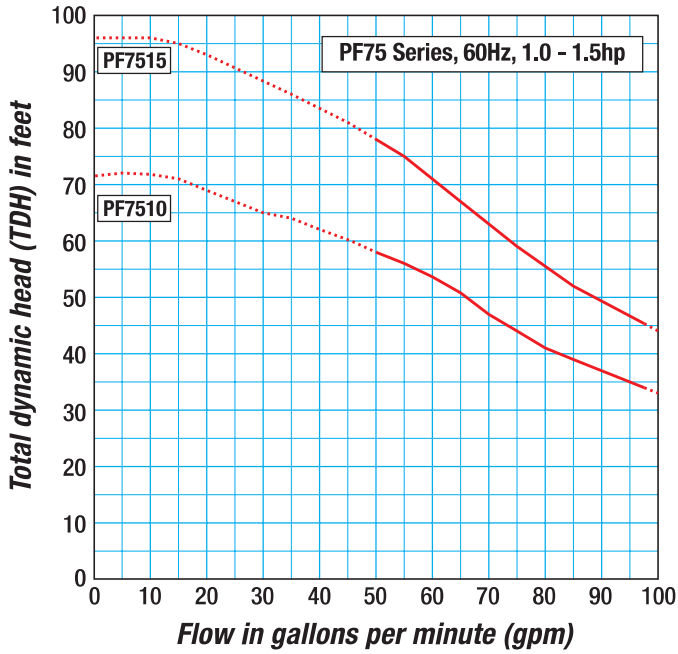
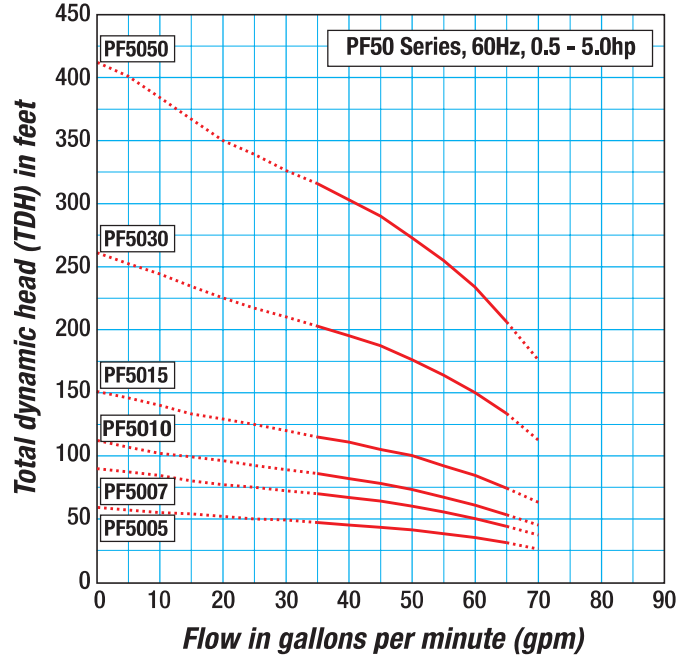
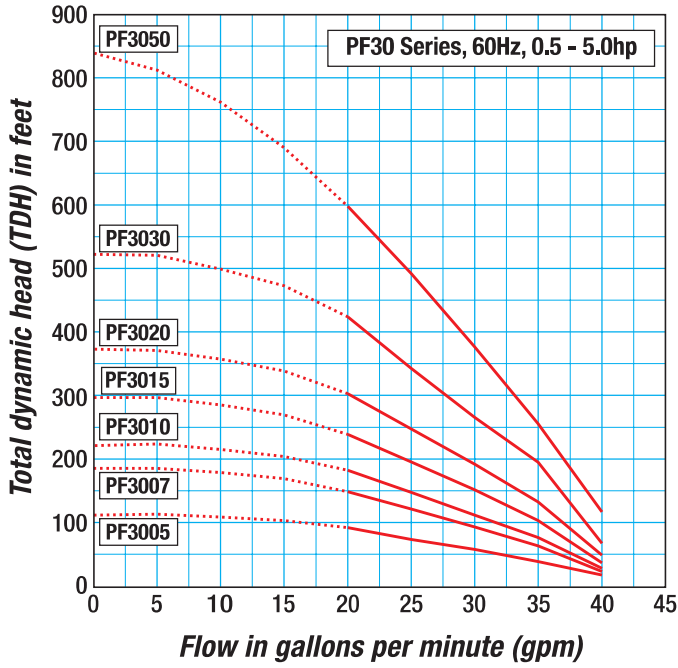

Float Switch Assemblies

Applications

Float switches are used to signal liquid level positions for alarm and pump control applications. Orenco float switch assemblies can be mounted in pump vaults, effluent screens, pump basins, and risers.

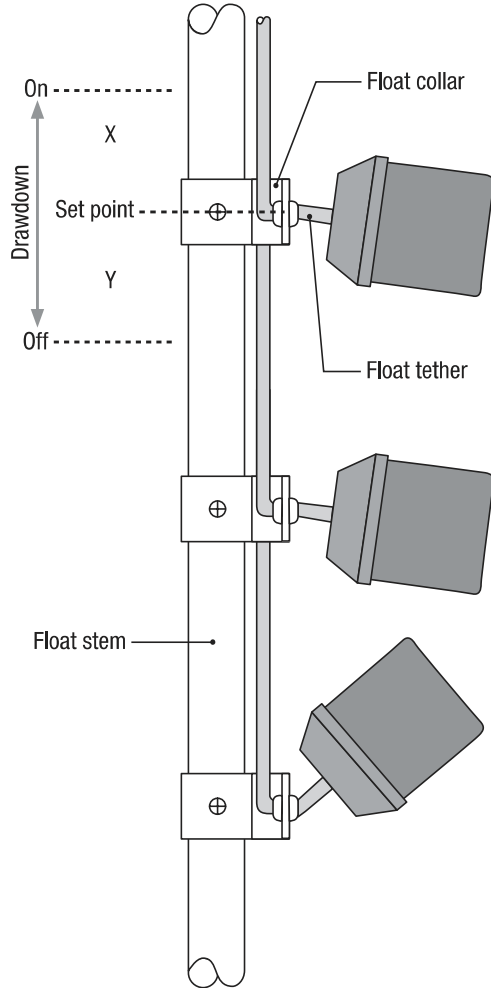

The "On" and "Off" positions shown describe normally open float switches. "On" and "Off" positions are reversed for normally closed float switches.

General

All models except "J" are UL listed and CSA certified for use in water or sewage; "J" switches are a CSA-certified direct alternative to "P" switches. Non-mercury float switches (models B, C, J, N, and P) are used where components containing mercury are prohibited.

Float switches are typically ordered in assemblies that include one or more switches mounted on a 1 in PVC float stem. ABS float collars are used to provide secure mounting that is easily adjustable.

Normally-open "P" float switches have a blue cap for easy identification; normally-closed "N" float switches have a red cap.

Standard Models

B, C, G, J, N, P

Product Code Diagram

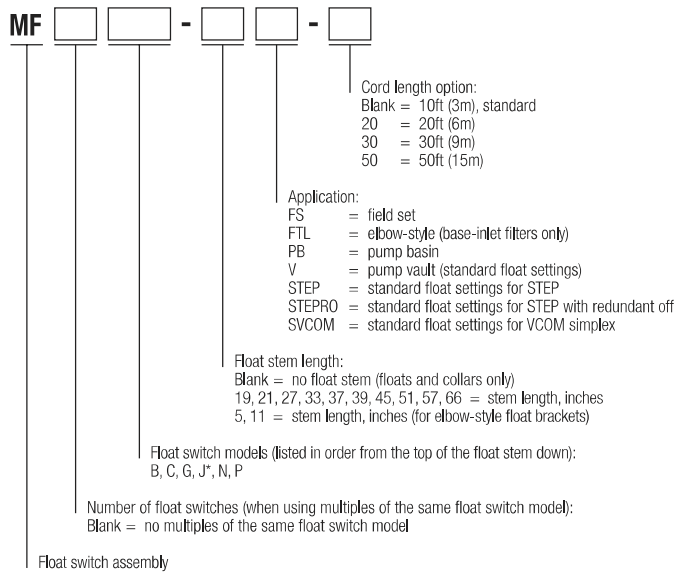

* CSA-certified, direct alternative to "P" float switch.

Note

When ordering float switch assemblies, remember to list float switches from the top of the float stem down. An "MFPBN-" product code indicates one "P" switch at the top of the stem, one "B" in the middle of the stem, and one "N" switch at the bottom of the stem; an "MF2PN-" indicates "P" switches at the top and middle of the stem, and one "N" switch at the bottom of the stem.

Signal- and Motor-Rated Float Switch Matrix

Model	State ¹	Type	IR ²	Volts	Amps	hp	Tether	X	Y	Drawdown ³
Signal-rated mechanical float switches⁴ (for control switch applications)										
P^a	Normally open	Mechanical	Yes	n/a	n/a	n/a	2.00in	1.50in	0.50in	2.00in
J^a	Normally open	Mechanical	Yes	n/a	n/a	n/a	2.00in	2.00in	0.10in	2.10in
N^a	Normally closed	Mechanical	Yes	n/a	n/a	n/a	2.00in	1.50in	0.50in	2.00in
Motor-rated float switches⁴ (for pump switch applications)										
B	Normally open	Mechanical	No	120V	13A	1/2hp	2.00in ^b	2.50in	1.50in	4.00in
				240V	13A	1hp	3.00in	3.00in	1.50in	4.50in
							4.00in	3.25in	1.50in	4.75in
C	Normally open	Mechanical	No	120V	13A	1/2hp	2.00in	3.00in	2.50in	5.50in
				240V	15A	2hp	3.00in ^b	3.50in	3.00in	6.50in
							4.00in	4.00in	3.50in	7.50in
							5.00in	4.50in	4.00in	8.50in
						6.00in	5.25in	4.25in	9.50in	
G	Normally open	Mercury	Yes	120V	15A	3/4hp	2.00in	1.50in	3.00in	4.50in
				240V	15A	2hp	3.00in ^b	1.75in	3.00in	4.75in
							4.00in	2.00in	3.50in	5.50in

a. Suitable for use with VCOM and MVP

b. Standard tether length

Notes

¹ State: normally open or normally closed

Float switches have an internal contact. The terms "normally open" (N/O) and "normally closed" (N/C) refer to the default state of the float switch contact. The default state refers to the contact positions in the float switch when it is resting (down). A normally open float switch has an open contact (off) in the down position, and a normally closed float switch has a closed contact (on) in the down position. Different panel functions require different types of float switches. Most applications require float switches that are normally open. One notable exception is the redundant off and low-level alarm function that requires a normally closed float switch, except with MVP and VCOM panels.

² IR (intrinsically safe relay)

Indicates that the float switch is approved for use with intrinsically safe, Class I, Division 1 applications, where reliable float switch operation with very low current is required.

³ Drawdown

Drawdown (in inches) refers to the difference in liquid level between a float switch's activation and deactivation points. Drawdown can be altered by adjusting the tether length of the float switch cord. When selecting float switches, keep in mind that any float switch that can directly start and stop a pump (one that has no motor contactor in the control panel) should have a drawdown capability, to avoid rapid cycling of the pump.

⁴ Signal-rated or motor-rated

Every float switch has a maximum amount of current it can handle. Exceeding these limits may cause premature failure. Signal-rated or "control" float switches are used to activate pump control panels and alarms. Only low-amperage signals pass through these switches, hence the switch is "signal-rated." All Orenco panels that use motor contactors can use signal-rated float switches. In some systems, a float switch is used to directly start and stop a pump. In this application, the current running the pump passes through the switch as well, so the switch must be "motor-rated." In most instances, a motor-rated float switch can be used as a signal-rated float switch.

MVP-Duplex Control Panel

Applications

Orenco's MVP-Duplex control panel has a dual-mode feature, making it ideal for both timed- and demand-dosing in two-pump alternating systems. All MVPs include an easy-to-use, programmable logic unit that incorporates many timing and logic functions, such as multiple timing intervals to adjust for changing flow conditions and a built-in elapsed time meter and counter.



The programmable logic unit is the brain of the MVP-Duplex control panel

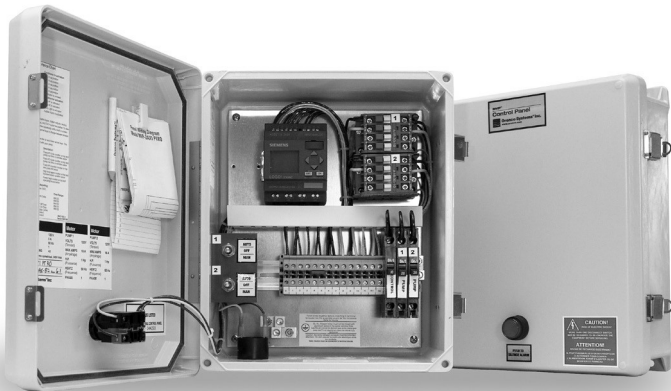

Orenco® MVP-DAX1DM control panel accommodates both timed- and demand-dosing applications



Features/Unique Specifications

To specify this panel for your installation, require the following:

- Programmable for timed- or demand-dosing applications
- Built-in elapsed time meter and counters
- Digital timed-dose function accurate within 1%
- Multiple timer settings for optimum dosing during normal and peak flow conditions
- Pump alternation continues during override conditions
- Built-in programming keys for field-adjustable timer settings without a portable computer
- Ability to use EEPROM card to change panel functions
- High- and low-level alarm conditions differentiated by steady or blinking LED light
- Silenced alarms automatically reactivated after 12 hours if condition is not corrected
- Standard 120 VAC output for remote alarm activation
- Timed delays on float inputs to prevent chattering
- Ability to use one model of float for all functions
- Visual indicators of float positions
- Redundant-off function as standard
- UL 508 listing in US and Canada

Standard Models

MVP-DAX1DM, MVP-DAX2DM

Product Code Diagram

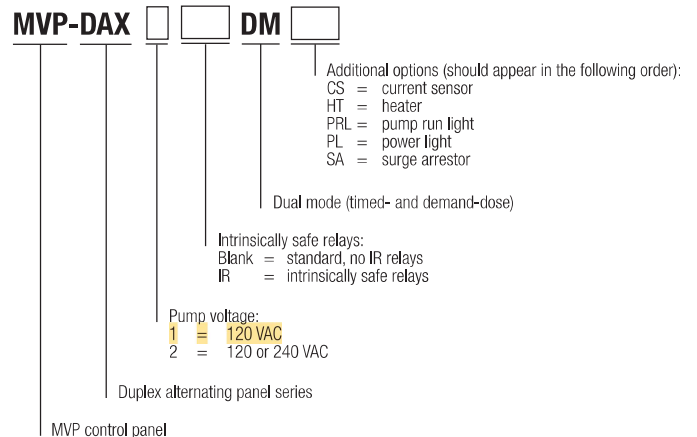

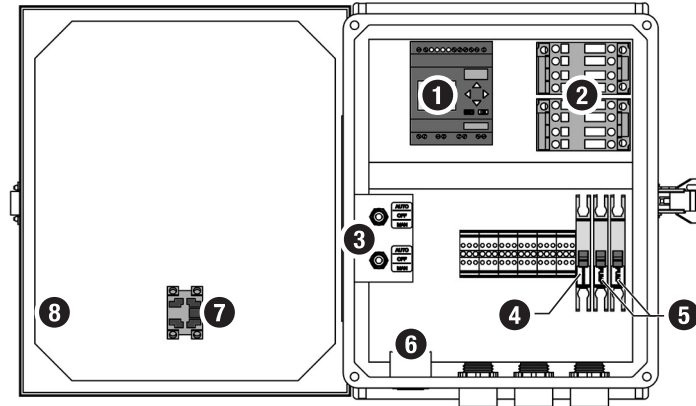

Orenco® MVP-DAX1DM 120 V panel

Standard Components

Feature	Specification(s)
1. Programmable Logic Unit	120 VAC programmable logic unit with built-in LCD screen and programming keys. Provides control functions and timing for panel operation.
2. Motor-Start Contactors	120 VAC: 16 FLA, 1 hp (0.75 kW), 60 Hz; 2.5 million cycles at FLA (10 million at 50% of FLA) 240 VAC: 16 FLA, 3 hp (2.24 kW), 60 Hz; 2.5 million cycles at FLA (10 million at 50% of FLA)
3. Toggle Switches	Single-pole, double-throw HOA switch. 20 A, 1hp (0.75 kW).
4. Controls Circuit Breaker	10 A, OFF/ON switch. Single-pole 120 V*. DIN rail mounting with thermal magnetic tripping characteristics.
5. Pump Circuit Breakers	20 A, OFF/ON switches. Single-pole 120 V or double-pole 240 V. DIN rail mounting with thermal magnetic tripping characteristics.
6. Audible Alarm	95 dB at 24 in. (610 mm), warble-tone sound.
7. Visual Alarm	7/8-in. (22-mm) diameter red lens, "Push-to-silence." UL Type 4X rated, 1 W LED light, 120 VAC.
8. Panel Enclosure	Measures 11.5 in. high × 9.5 in. wide × 5.4 in. deep (290 × 240 × 135 mm). UL Type 4X rated. Constructed of UV-resistant fiberglass; hinges and latch are stainless steel. Conduit couplings provided.
Dual-Mode Operation	Programmable for timed- and demand-dosing.
MVP-DAX1DM Panel Ratings	120 VAC, 1 hp (0.75 kW), 16 A, single phase, 60 Hz.
MVP-DAX2DM Panel Ratings	240 VAC, 3 hp (2.24 kW), 16 A, single phase, 60 Hz.

Optional Components

Feature	Specification(s)	Product Code Adder
Intrinsically Safe Control Relays	120 VAC. Listed per UL 698A, for Class 1 Div. 1, Groups A, B, C, D hazardous locations. Larger enclosure required.	IR
Current Sensor	120 VAC. Go/no-go operation. Pump fail indicator light on panel. Manual reset switch.	CS
Heater	Anti-condensation heater. Self-adjusting; radiates additional wattage as temperature drops.	HT
Pump Run Lights	7/8-in. (22-mm) diameter green lens. UL Type 4X rated, 1 W LED light, 120 VAC.	PRL
Power Light	7/8-in. (22-mm) diameter green lens. UL Type 4X rated, 1 W LED light, 120 VAC.	PL
Surge Arrestor	120 V. Status light on unit. Protects incoming power supply from electrical surges.	SA

* 240 VAC units available for int'l markets

** 120 VAC output for remote alarms comes standard.

Dose Chamber Packages

Orenco DuraFiber™ FLD Access Lids

Applications

Orenco DuraFiber FLD Access Lids provide secure, durable, watertight coverings for ribbed PVC, HDPE, and Orenco FRP risers, pump basins, and access ports. They are capable of supporting a 2500lb (1134kg) load; however, they are not recommended for vehicular traffic.

FLD24 24in (600mm) lids require an RLA24 adapter to connect to Perma-Loc™ pipe. FLD30 30in (750mm) lids are not compatible with RLA30 Riser-Lid-Adapters or 30in (750mm) Perma-Loc pipe.

General

DuraFiber FLD lids are designed for extreme durability and damage resistance, with UV- and corrosion-resistant materials, optional EPDM gaskets for watertight lid-to-riser connections, and flat-style flanges for easy access with clean, flush-to-grade installations. They also have centering rings for easy alignment. FLD lids feature a non-skid surface and a molded-in caution statement, with room for a customer logo. All come with four 5/16in stainless steel socket cap screws and a hex key wrench.

FLD lids are available with optional insulation, installed at the factory or in kits that can be installed in the field.

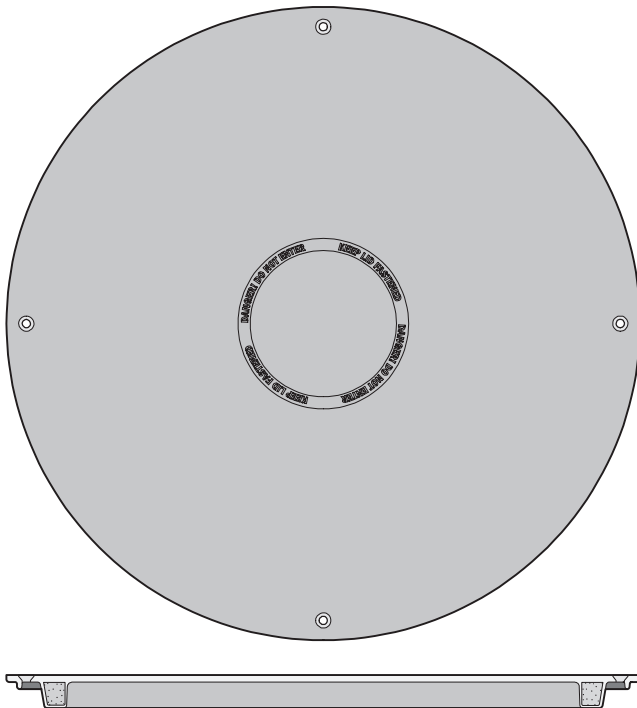

DuraFiber FLD lid: top view and side-cutaway view

Standard Models

FLD18G, FLD24G, FLD24G-ATX, FLD24G-W, FLD30G, FLD30G-ATX, FLD30G-PRELOS, FLD30G-W

Product Code Diagram

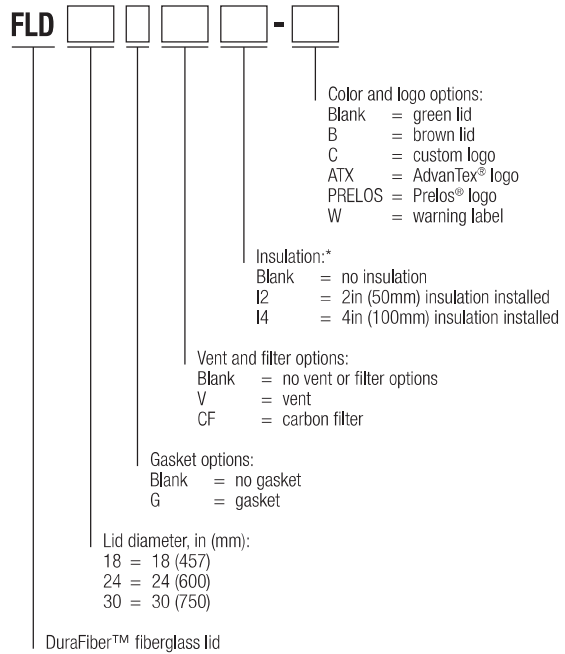

*Insulation has an R-value of 10 per 2in (RSI of 1.8 per 50mm) increment

Materials of Construction

Lid	Fiber-reinforced polymer (FRP)
Gasket (FLD18)	Urethane
Gasket (FLD24, FLD30)	EPDM
Centering ring core	Structural foam
Mounting hardware	Stainless steel
Insulation, optional	Closed-cell foam
Insulation mounting hardware	Stainless steel

Specifications

Model	FLD18XX	FLD24XX	FLD30XX
A in (mm)	20.2 (514)	25.75 (654)	32.75 (832)
B in (mm)	1.5 (38)	1.5 (38)	1.5 (38)
C in (mm)	17.5 (445)	23.25 (591)	29.25 (743)
Insulation R-value per 2in (RSI per 50mm) increment	10 (1.8)	10 (1.8)	10 (1.8)
Gasket width, in (mm)	0.75 (19)	0.69 (18)	0.69 (18)
Bolt hole diameter, in (mm)	0.3125 (8)	0.3125 (8)	0.3125 (8)
Weight, lbs (kg)	7 (3)	11 (5)	20 (9)
Bolt holes per lid	4	4	4

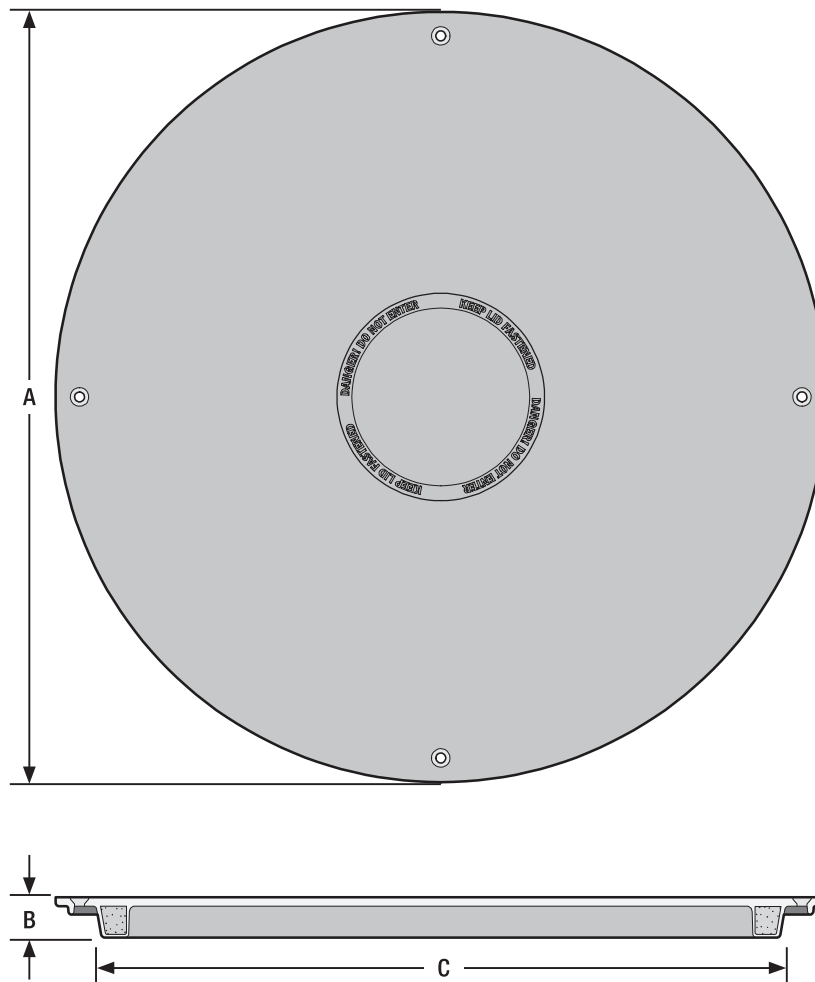

Universal Biotube® Pump Vaults

For use with Orenco® 4-inch (100-mm) Submersible Effluent Pumps

Applications

Orenco Biotube® Pump Vaults are used to filter effluent that is pumped from septic tanks or separate dosing tanks in STEP systems and onsite wastewater treatment systems. They remove two-thirds of suspended solids, on average. Pump vaults house a Biotube effluent filter and one or two Orenco high-head effluent pumps and can be used in single-compartment septic tanks with flows up to 40 gpm (2.5 L/sec). When flows are greater than 40 gpm (2.5 L/sec), a double-compartment septic tank or separate dosing tank is recommended.

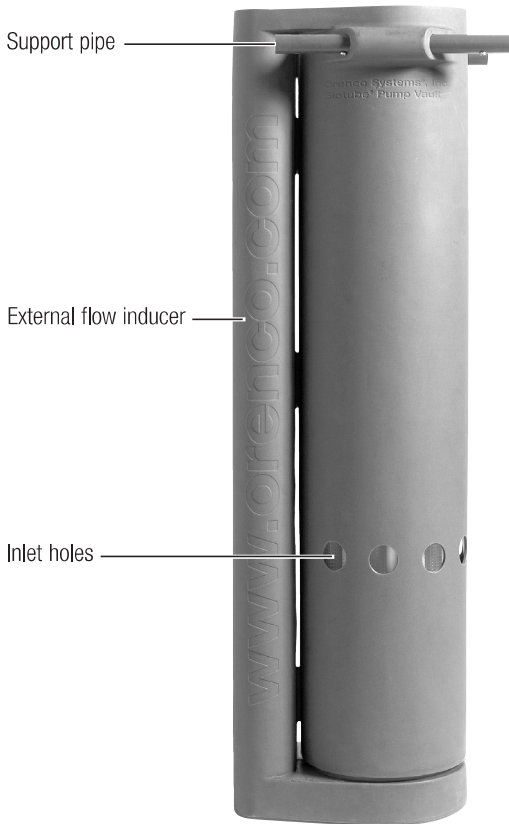

Side view

General

The Orenco Biotube Pump Vault includes a molded polyethylene housing with an internal Biotube filter cartridge constructed of polypropylene and PVC. Schedule 80 PVC support pipes are included to suspend the vault in a tank opening. “Earless” 68-inch (1727-mm) vaults, which rest on the bottom of the tank instead of on support pipes, are also available. The filter cartridge can be removed without pulling the pump or the vault. Effluent enters through inlet holes around the perimeter of the Biotube vault and flows through the Biotubes to the external flow inducer. The external flow inducer accommodates one or two pumps. Orenco Biotube Pump Vaults are covered by U.S. patents #4,439,323 and 5,492,635.

Standard Models

PVU48-1818, PVU57-1819, PVU68-2419, PVU84-2419, PVU95-3625

Product Code Diagram

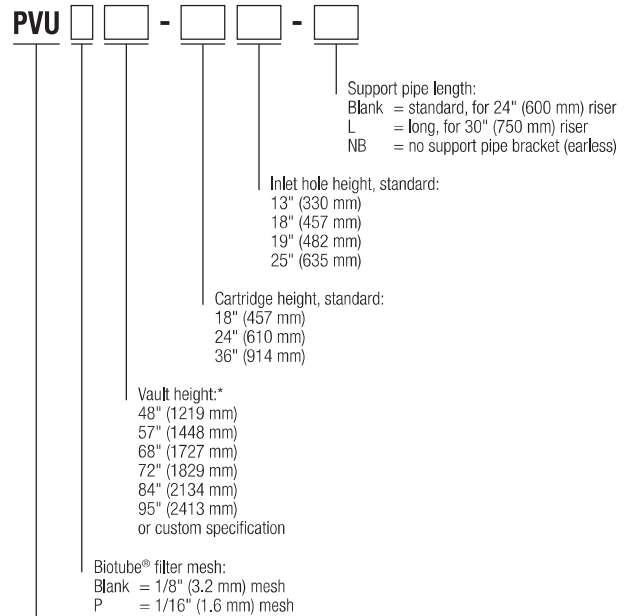

Universal Pump Vault

* Custom heights from 42" to 135" available

Tank Access and Riser Diameters

Diameter, in. (mm)	PVU with simplex pump	PVU with duplex pumps
Tank access, minimum	19 (483)	19 (483)
Tank access, recommended	20 (508)	20 (508)
Riser, minimum	24 (600)	30 (750)

Materials of Construction

Support pipe	Schedule 80 PVC
Biotube® vault	Polyethylene
Biotube filter cartridge	Polypropylene/PVC
Float stem	Schedule 40 PVC
Drain valve ball	Polypropylene

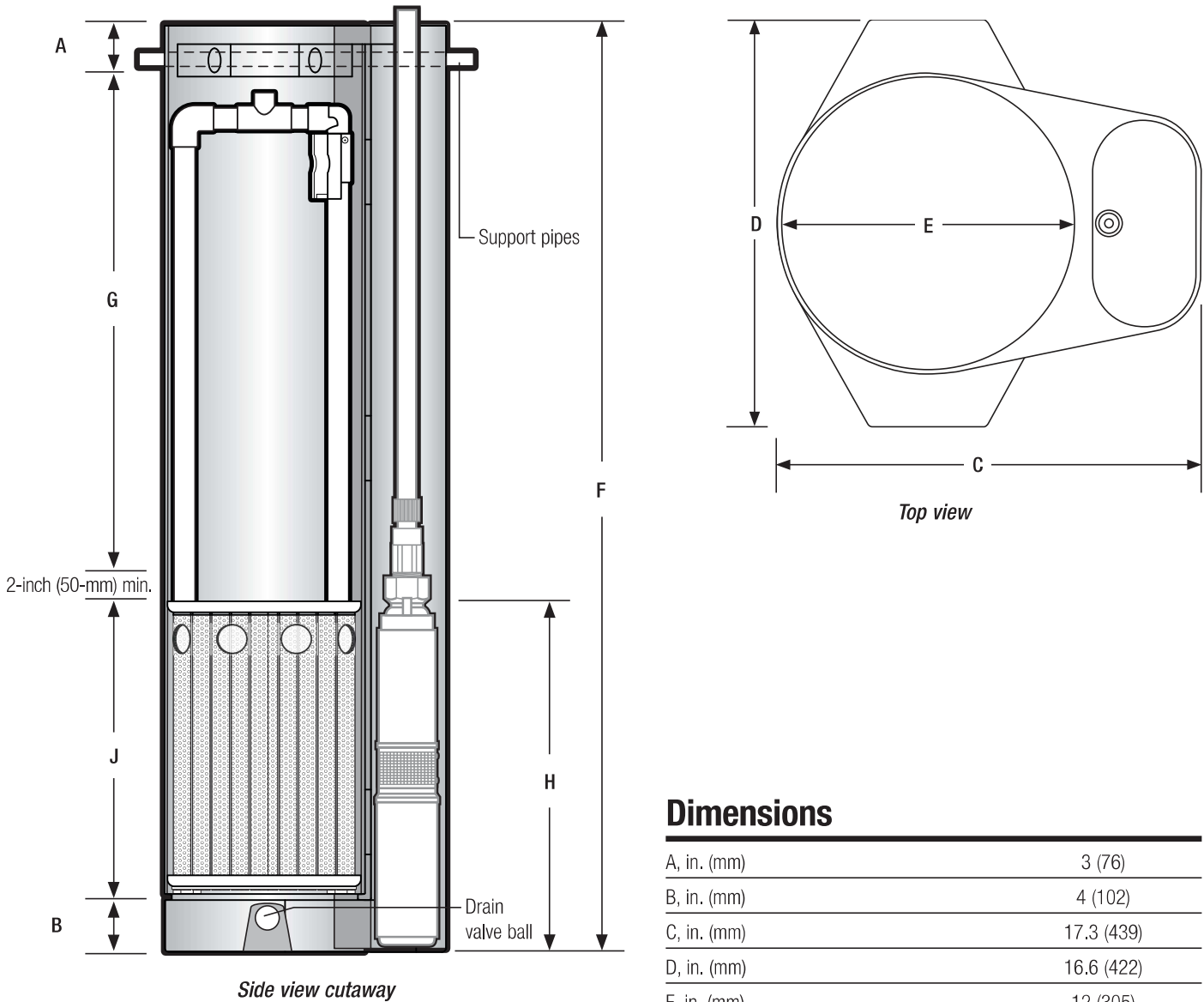

Dimensions

A, in. (mm)	3 (76)
B, in. (mm)	4 (102)
C, in. (mm)	17.3 (439)
D, in. (mm)	16.6 (422)
E, in. (mm)	12 (305)

Specifications

Model	PVU48-1818	PVU57-1819	PVU68-2419	PVU84-2419	PVU95-3625
F, vault height, in. (mm)	48 (1219)	57 (1448)	68 (1727)	84 (1727)	95 (2413)
G, lowest float setting point, in. (mm)	21 (533)	29 (737)	35 (889)	51 (1295)	50 (1270)
H, inlet hole height, in. (mm)*	18 (457)	19 (483)	19 in. (483)	19 (482)	25 (635)
J, Biotube® cartridge height, in. (mm)	18 (457)	18 (457)	24 (610)	24 (610)	36 (914)
Biotube mesh opening, in. (mm)	0.125 (3)	0.125 (3)	0.125 (3)	0.125 (3)	0.125 (3)
Filter flow area, ft ² (m ²)	4.4 (0.4)	4.4 (0.4)	5.9 (0.5)	5.9 (0.5)	9.0 (0.84)
Filter surface area, ft ² (m ²)	14.5 (1.35)	14.5 (1.35)	19.7 (1.83)	19.7 (1.83)	30 (2.79)
Maximum flow rate, gpm (L/sec)	140 (8.8)	140 (8.8)	140 (8.8)	140 (8.8)	140 (8.8)

* May vary depending on the configuration of the tank.

Float Switch Assemblies

Applications

Float switches are used to signal liquid level positions for alarm and pump control applications. Orenco float switch assemblies can be mounted in pump vaults, effluent screens, pump basins, and risers.

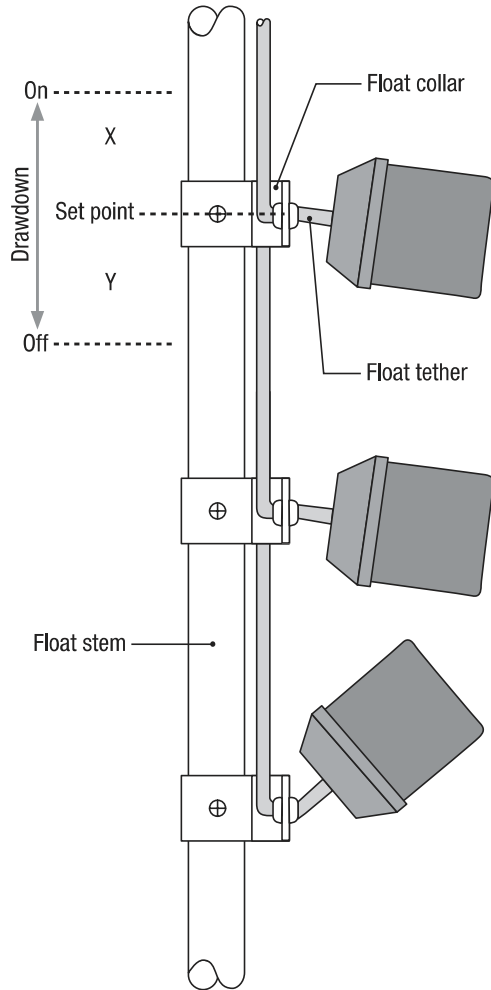

The "On" and "Off" positions shown describe normally open float switches. "On" and "Off" positions are reversed for normally closed float switches.

General

All models except "J" are UL listed and CSA certified for use in water or sewage; "J" switches are a CSA-certified direct alternative to "P" switches. Non-mercury float switches (models B, C, J, N, and P) are used where components containing mercury are prohibited.

Float switches are typically ordered in assemblies that include one or more switches mounted on a 1 in PVC float stem. ABS float collars are used to provide secure mounting that is easily adjustable.

Normally-open "P" float switches have a blue cap for easy identification; normally-closed "N" float switches have a red cap.

Standard Models

B, C, G, J, N, P

Product Code Diagram

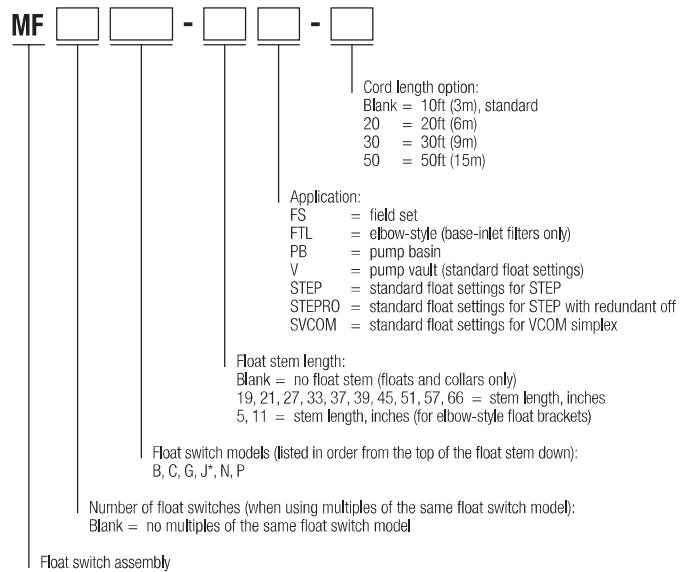

* CSA-certified, direct alternative to "P" float switch.

Note

When ordering float switch assemblies, remember to list float switches from the top of the float stem down. An "MFPBN-" product code indicates one "P" switch at the top of the stem, one "B" in the middle of the stem, and one "N" switch at the bottom of the stem; an "MF2PN-" indicates "P" switches at the top and middle of the stem, and one "N" switch at the bottom of the stem.

Signal- and Motor-Rated Float Switch Matrix

Model	State ¹	Type	IR ²	Volts	Amps	hp	Tether	X	Y	Drawdown ³
Signal-rated mechanical float switches⁴ (for control switch applications)										
P^a	Normally open	Mechanical	Yes	n/a	n/a	n/a	2.00in	1.50in	0.50in	2.00in
J^a	Normally open	Mechanical	Yes	n/a	n/a	n/a	2.00in	2.00in	0.10in	2.10in
N^a	Normally closed	Mechanical	Yes	n/a	n/a	n/a	2.00in	1.50in	0.50in	2.00in
Motor-rated float switches⁴ (for pump switch applications)										
B	Normally open	Mechanical	No	120V	13A	1/2hp	2.00in ^b	2.50in	1.50in	4.00in
				240V	13A	1hp	3.00in	3.00in	1.50in	4.50in
							4.00in	3.25in	1.50in	4.75in
C	Normally open	Mechanical	No	120V	13A	1/2hp	2.00in	3.00in	2.50in	5.50in
				240V	15A	2hp	3.00in ^b	3.50in	3.00in	6.50in
							4.00in	4.00in	3.50in	7.50in
							5.00in	4.50in	4.00in	8.50in
							6.00in	5.25in	4.25in	9.50in
G	Normally open	Mercury	Yes	120V	15A	3/4hp	2.00in	1.50in	3.00in	4.50in
				240V	15A	2hp	3.00in ^b	1.75in	3.00in	4.75in
							4.00in	2.00in	3.50in	5.50in

a. Suitable for use with VCOM and MVP

b. Standard tether length

Notes

¹ State: normally open or normally closed

Float switches have an internal contact. The terms "normally open" (N/O) and "normally closed" (N/C) refer to the default state of the float switch contact. The default state refers to the contact positions in the float switch when it is resting (down). A normally open float switch has an open contact (off) in the down position, and a normally closed float switch has a closed contact (on) in the down position. Different panel functions require different types of float switches. Most applications require float switches that are normally open. One notable exception is the redundant off and low-level alarm function that requires a normally closed float switch, except with MVP and VCOM panels.

² IR (intrinsically safe relay)

Indicates that the float switch is approved for use with intrinsically safe, Class I, Division 1 applications, where reliable float switch operation with very low current is required.

³ Drawdown

Drawdown (in inches) refers to the difference in liquid level between a float switch's activation and deactivation points. Drawdown can be altered by adjusting the tether length of the float switch cord. When selecting float switches, keep in mind that any float switch that can directly start and stop a pump (one that has no motor contactor in the control panel) should have a drawdown capability, to avoid rapid cycling of the pump.

⁴ Signal-rated or motor-rated

Every float switch has a maximum amount of current it can handle. Exceeding these limits may cause premature failure. Signal-rated or "control" float switches are used to activate pump control panels and alarms. Only low-amperage signals pass through these switches, hence the switch is "signal-rated." All Orenco panels that use motor contactors can use signal-rated float switches. In some systems, a float switch is used to directly start and stop a pump. In this application, the current running the pump passes through the switch as well, so the switch must be "motor-rated." In most instances, a motor-rated float switch can be used as a signal-rated float switch.

PF-Series Submersible Effluent Pumps: 1-Phase, 60-Hz, 4-inch (100-mm)

Applications

Our PF-Series 4-inch (100-mm) Submersible Effluent Pumps are designed to transport screened effluent (with low TSS counts) from septic tanks or dosing tanks. These pumps are constructed of light-weight, corrosion-resistant stainless steel and engineered plastics, and are field-serviceable and repairable with common tools. They're also CSA- and UL-certified to U.S. and Canadian safety standards for effluent pumps.

PF-Series pumps are used in a variety of applications, including pressurized drainfields, packed-bed filters, mounds, aerobic units, effluent irrigation, liquid-only (effluent) sewers, wetlands, lagoons, and more. These pumps are designed to be used with a Biotube® pump vault or after a secondary treatment system.



Features/Specifications

To specify this pump for your installation, require the following:

- Minimum 24-hour run-dry capability (liquid end) with no deterioration in pump life or performance*
- 1/8-inch (3-mm) bypass orifice to ensure flow recirculation for motor cooling and to prevent air bind
- Liquid-end repair kits available for better long-term cost of ownership
- TRI-SEAL™ floating impeller design on 10, 20, and 30 gpm (0.6, 1.3, and 1.9 L/sec) models; floating stack design on 50 and 75 gpm (3.2 and 4.7 L/sec) models
- Franklin Electric Super Stainless motor, rated for continuous use and frequent cycling
- Type SOOW 600-V motor cable (model PF751512 uses 14 AWG, SJ00W, 300-V cord)

* Not applicable for 5-hp (3.73 kW) models

Standard Models

See specifications chart on page 2 for a list of standard pumps. For a complete list of available pumps, call Orenco.

Product Code Diagram

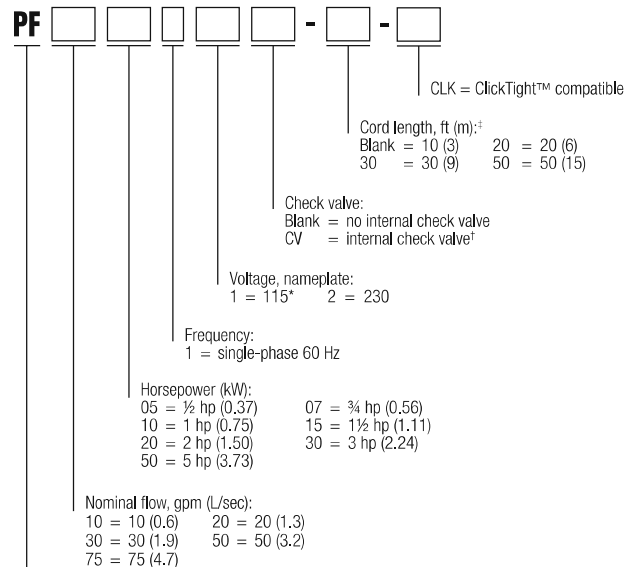

Pump, PF Series

* ½-hp (0.37 kW) only

[†] Available for 10 gpm (0.6 L/sec), 1/2 hp (0.37 kW)

[‡] Note: 20-ft cords are available only for pumps through 1½ hp



C US
LR80980
LR2053896



Powered by
Franklin Electric

Specifications

Pump Model	Design gpm (L/sec)	Horsepower (kW)	Phase	Nameplate voltage	Actual voltage	Design flow amps	Max amps	Discharge size and material ¹	Length in. (mm)	Min. liquid level in. (mm)	Weight lb (kg)	Rated cycles per day
PF100511 ⁹	10 (0.6)	0.50 (0.37)	1	115	120	12.7	12.7	1 ¼ in. GFP	23.0 (660)	16 (406)	26 (12)	300
PF100511CV ⁹	10 (0.6)	0.50 (0.37)	1	115	120	12.7	12.7	1 ¼ in. GFP	23.0 (660)	16 (406)	26 (12)	300
PF100512 ⁹	10 (0.6)	0.50 (0.37)	1	230	240	6.3	6.3	1 ¼ in. GFP	23.0 (660)	16 (406)	26 (12)	300
PF100712 ^{4,5,9}	10 (0.6)	0.75 (0.56)	1	230	240	8.3	8.3	1 ¼ in. GFP	25.9 (658)	17 (432)	30 (14)	300
PF101012 ^{5,6,9}	10 (0.6)	1.00 (0.75)	1	230	240	9.6	9.6	1 ¼ in. GFP	27.9 (709)	18 (457)	33 (15)	100
PF200511 ⁹	20 (1.3)	0.50 (0.37)	1	115	120	12.3	12.5	1 ¼ in. GFP	22.3 (566)	18 (457)	25 (11)	300
PF200512 ⁹	20 (1.3)	0.50 (0.37)	1	230	240	6.4	6.5	1 ¼ in. GFP	22.5 (572)	18 (457)	26 (12)	300
PF201012 ^{4,5,9}	20 (1.3)	1.00 (0.75)	1	230	240	10.5	10.5	1 ¼ in. GFP	28.4 (721)	20 (508)	33 (15)	100
PF201512 ^{4,5}	20 (1.3)	1.50 (1.11)	1	230	240	12.4	12.6	1 ¼ in. GFP	34.0 (864)	24 (610)	41 (19)	100
PF300511 ⁹	30 (1.9)	0.50 (0.37)	1	115	120	11.8	11.8	1 ¼ in. GFP	21.3 (541)	20 (508)	28 (13)	300
PF300512 ⁹	30 (1.9)	0.50 (0.37)	1	230	240	6.2	6.2	1 ¼ in. GFP	21.3 (541)	20 (508)	25 (11)	300
PF300712 ⁹	30 (1.9)	0.75 (0.56)	1	230	240	8.5	8.5	1 ¼ in. GFP	24.8 (630)	21 (533)	29 (13)	300
PF301012 ^{4,9}	30 (1.9)	1.00 (0.75)	1	230	240	10.4	10.4	1 ¼ in. GFP	27.0 (686)	22 (559)	32 (15)	100
PF301512 ^{4,5}	30 (1.9)	1.50 (1.11)	1	230	240	12.6	12.6	1 ¼ in. GFP	32.8 (833)	24 (610)	40 (18)	100
PF302012 ^{5,6,7}	30 (1.9)	2.00 (1.49)	1	230	240	11.0	11.0	1 ¼ in. SS	35.5 (902)	26 (660)	44 (20)	100
PF303012 ^{5,6,7,8}	30 (1.9)	3.00 (2.23)	1	230	240	16.8	16.8	1 ¼ in. SS	44.5 (1130)	33 (838)	54 (24)	100
PF305012 ^{5,6,7,8}	30 (1.9)	5.00 (3.73)	1	230	240	25.6	25.8	1 ¼ in. SS	66.5 (1689)	53 (1346)	82 (37)	100
PF500511 ⁹	50 (3.2)	0.50 (0.37)	1	115	120	12.1	12.1	2 in. SS	20.3 (516)	24 (610)	27 (12)	300
PF500512 ⁹	50 (3.2)	0.50 (0.37)	1	230	240	6.2	6.2	2 in. SS	20.3 (516)	24 (610)	27 (12)	300
PF500712 ⁹	50 (3.2)	0.75 (0.56)	1	230	240	8.5	8.5	2 in. SS	23.7 (602)	25 (635)	31 (14)	300
PF501012 ⁹	50 (3.2)	1.00 (0.75)	1	230	240	10.1	10.1	2 in. SS	27.0 (686)	26 (660)	35 (16)	100
PF501512 ⁴	50 (3.2)	1.50 (1.11)	1	230	240	12.5	12.6	2 in. SS	32.5 (826)	30 (762)	41 (19)	100
PF503012 ^{4,5,7,8}	50 (3.2)	3.00 (2.23)	1	230	240	17.7	17.7	2 in. SS	43.0 (1092)	37 (940)	55 (25)	100
PF505012 ^{5,6,7,8}	50 (3.2)	5.00 (3.73)	1	230	240	26.2	26.4	2 in. SS	65.4 (1661)	55 (1397)	64 (29)	100
PF751012 ⁹	75 (4.7)	1.00 (0.75)	1	230	240	9.9	10.0	2 in. SS	27.0 (686)	27 (686)	34 (15)	100
PF751512	75 (4.7)	1.50 (1.11)	1	230	240	12.1	12.3	2 in. SS	33.4 (848)	30 (762)	44 (20)	100

- 1 GFP = glass-filled polypropylene; SS = stainless steel. The 1 ¼-in. NPT GFP discharge is 2 7/8 in. octagonal across flats; the 1 ¼-in. NPT SS discharge is 2 1/8 in. octagonal across flats; and the 2-in. NPT SS discharge is 2 7/8 in. hexagonal across flats. Discharge is female NPT threaded, U.S. nominal size, to accommodate Orenco® discharge hose and valve assemblies. Consult your Orenco Distributor about fittings to connect hose and valve assemblies to metric-sized piping.
- 2 Minimum liquid level is for single pumps when installed in an Orenco Biotube® Pump Vault or Universal Flow Inducer. In other applications, minimum liquid level should be top of pump. Consult Orenco for more information.
- 3 Weight includes carton and 10-ft (3-m) cord.
- 4 High-pressure discharge assembly required.
- 5 Do not use cam-lock option (Q) on discharge assembly.
- 6 Custom discharge assembly required for these pumps. Contact Orenco.
- 7 Capacitor pack (sold separately or installed in a custom control panel) required for this pump. Contact Orenco.
- 8 Torque locks are available for all pumps and are supplied with 3-hp and 5-hp pumps.
- 9 ClickTight™ compatible.

Materials of Construction

Discharge	Glass-filled polypropylene or stainless steel
Discharge bearing	Engineered thermoplastic (PEEK)
Diffusers	Glass-filled PPO (Noryl GFN3)
Impellers	Celcon® acetal copolymer on 10-, 20-, and 30-gpm models; 50-gpm impellers are Noryl GFN3
Intake screen	Polypropylene
Suction connection	Stainless steel
Drive shaft	7/16-in. hexagonal stainless steel, 300 series
Coupling	Sintered stainless steel, 300 series
Shell	Stainless steel, 300 series
Motor	Franklin motor exterior constructed of stainless steel. Motor filled with deionized water and propylene glycol for constant lubrication. Hermetically sealed motor housing ensures moisture-free windings. All thrust absorbed by Kingsbury-type thrust bearing. Rated for continuous duty. Single-phase motors are equipped with surge arrestors for added security. Single-phase motors through 1.5 hp (1.11 kW) have built-in thermal over-load protection, which trips at 203-221° F (95-105° C).

Using a Pump Curve

A pump curve helps you determine the best pump for your system. Pump curves show the relationship between flow and pressure (total dynamic head or “TDH”), providing a graphical representation of a pump’s optimal performance range. Pumps perform best at their nominal flow rate. These graphs show optimal pump operation ranges with a solid line and show flow rates outside of these ranges with a dashed line. For the most accurate pump specification, use Orenco’s PumpSelect™ software.

Pump Curves

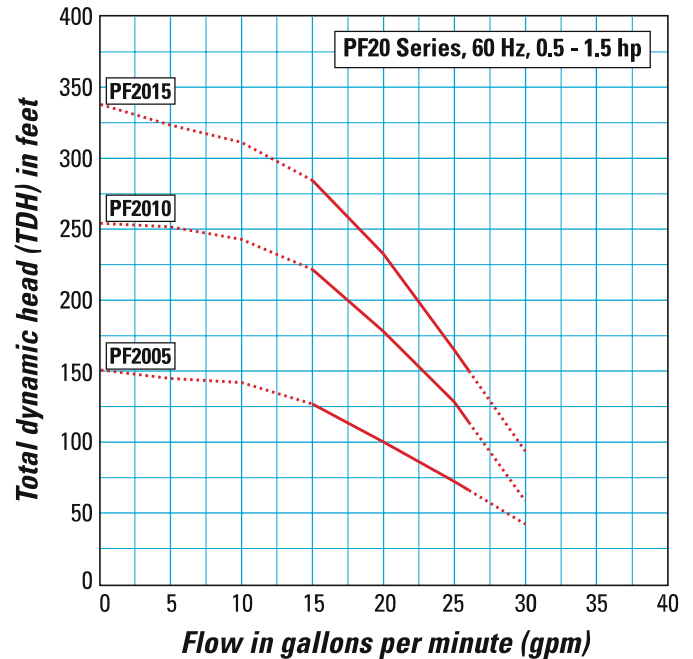
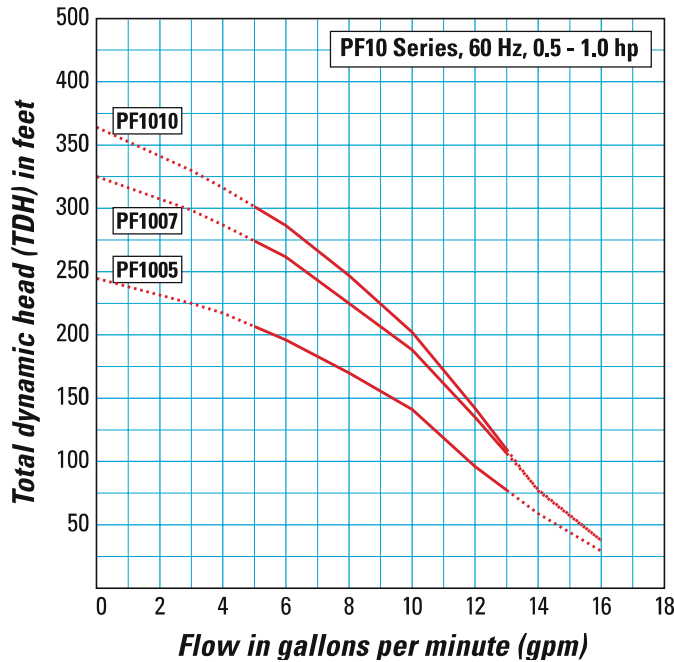

Pump Curves, cont.

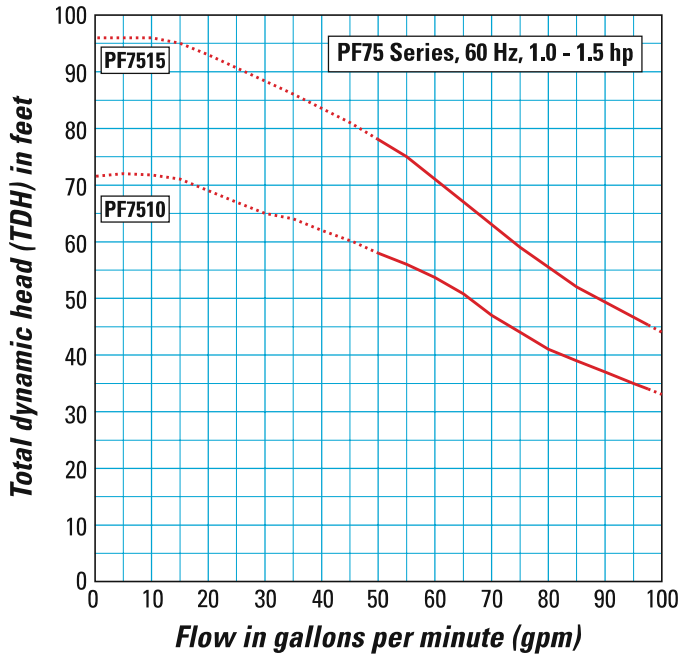
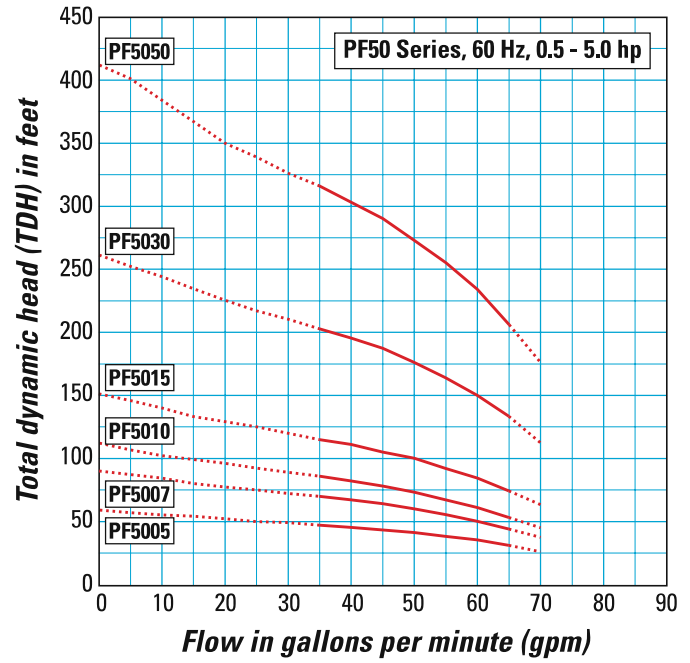
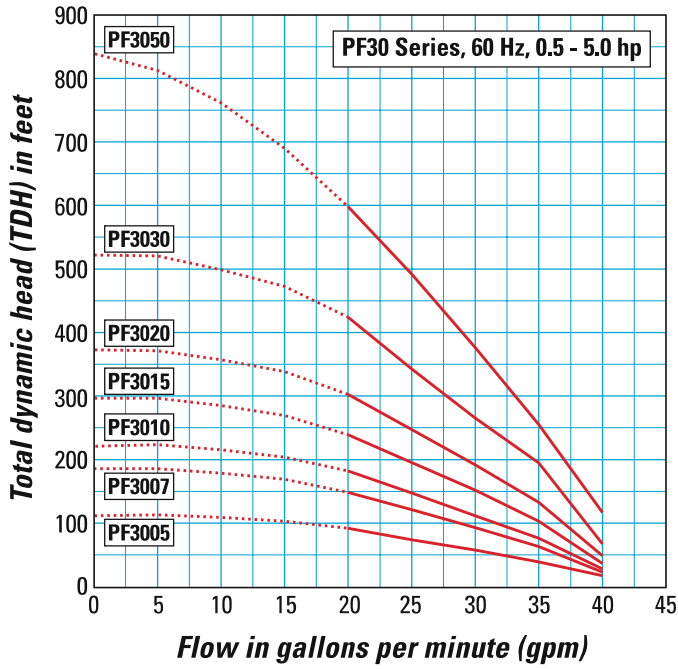

Internal Splice Boxes

Applications

Orenco® internal splice boxes* are used in risers to house spliced wire connections between an electrical control panel and such equipment as effluent pumps and float switches. They conform to UL 514C, CSA C22.2 No. 85 1968, and meet UL Type 4X rating. Cord grips can withstand temperatures of up to 212° F (100° C). Standard ½-in. (13-mm) cord grips can accommodate round cord diameters from 0.17 to 0.47 in. (4.3 to 12 mm). Large ¾-in. (19-mm) cord grips can accommodate round cord diameters from 0.45 to 0.70 in. (11 to 18 mm). Cord grips are also available to accommodate single- and three-phase CE-rated 1.5 × 3 flat cords.

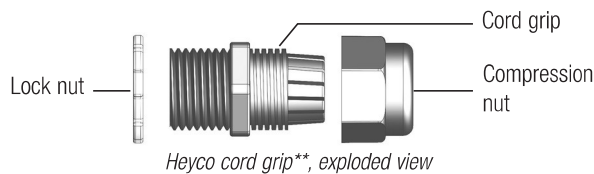
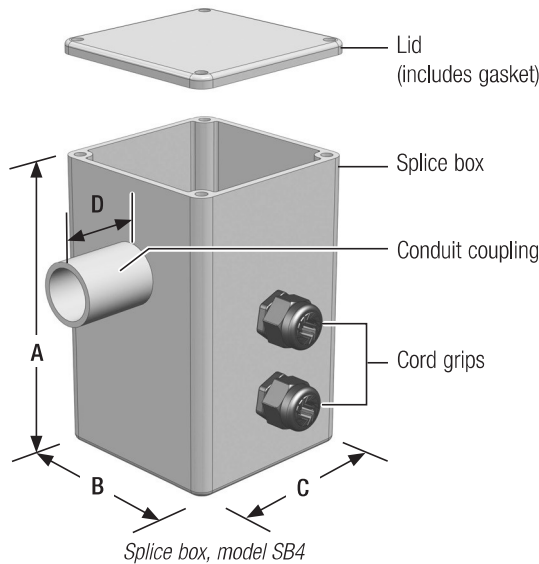

General

Orenco splice boxes come standard with one to six watertight cord grips. Included are waterproof wire nuts, a sealing gasket, and four stainless steel lid screws.

Splice boxes also come standard with ½-in. (13-mm) cord grips and a 1½-in. (41-mm) long conduit coupling. Large ¾-in. (19-mm) cord grips and ¾-in. (83-mm) long conduit couplings (for square or round concrete risers) are available.

Standard Models

SB1, SB2, SB3, SB4, SB5, SB6.

Nomenclature

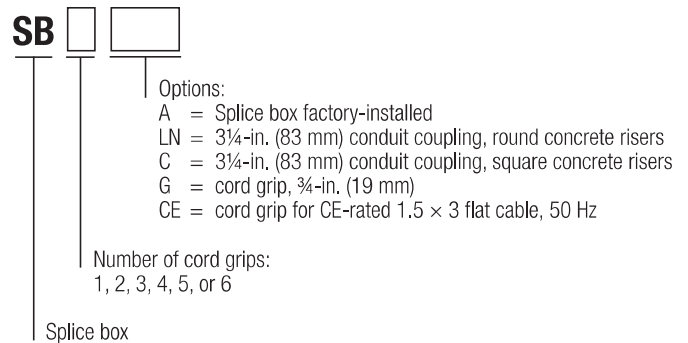

Materials of Construction

Lid	PVC per ASTM D-1784
Splice box	PVC per ASTM D-1784
Conduit coupling	PVC per ASTM D-1784
Cord grip	Nylon
Lock nut	Stainless steel
Sealing gasket (not shown)	Proprietary elastomer
Lid screws (not shown)	Stainless steel

Specifications

Model	SB1	SB2	SB3	SB4	SB5	SB6
A, in. (mm)	6¼ (159)	6¼ (159)	6¼ (159)	6¼ (159)	6¼ (159)	6¼ (159)
B, in. (mm)	4 (102)	4 (102)	4 (102)	4 (102)	4 (102)	4 (102)
C, in. (mm)	4 (102)	4 (102)	4 (102)	4 (102)	4 (102)	4 (102)
D, standard size, in. (mm)	1½ (41)	1½ (41)	1½ (41)	1½ (41)	1½ (41)	1½ (41)
Conduit diameter, nominal, in. (DN)	¾ (20)	¾ (20)	¾ (20)	¾ (20)	1 (25)	1 (25)
Number of cord grips	1	2	3	4	5	6

*For information on Orenco® external splice boxes, see NTD-SBEX-1, External Splice Boxes

**Cord grips are listed under UL file number E-51579 and CSA file number LR-93876